



FOREST RIVER BUS

Owner's Manual

Table of Contents

Introduction	1
About this Manual	1
Notice of the following	1
Unit Identification Numbers	2
Production Number	2
Vehicle Identification Number (VIN)	2
Safety Dangers and Precautions	3
Safety Danger Symbols and Labels	3
Notice Information	3
Alterations or Nonstandard Components	4
Reporting Safety Defects	4
National Highway Traffic Safety Administration Contact Information	4
Forest River Bus Contact Information	4
Vehicle Weight and Loading Information and Restrictions	5
Vehicle Safety Standard Certification Labels	5
Loading Procedures	6
Weighing Procedures	6
Tire and Rim Certifications Label	7
Tire Pressure Information	7
Be Prepared for Emergencies	8
Emergency Preparations	8
Escape Routes	8
Emergency Exits	8
Fire Extinguishers	9
Fire Prevention Suggestions	9
Reflector Kits	9
Fuel Tank Safety	10
Other Safety Tips	10

Be Responsible for Safe Transportation	11
Helpful Driving Tips	11
Pre-Travel Inspections	12-13
Seat Belts	14
Buckle Up	14
Using Seat Belts (Per NHTSA website)	14
Maintenance	14
Proper Preventative Maintenance and Care	15
Service and Maintenance Programs	15
Electrical System	16
Forest River Bus Electrical Panel	16
Call for Assistance	16
Replacing a Fuse	16
Maintenance	16
Glaval Switches, Controls and Indicator Lights	17
Chassis Manufacture Lights, Signals and Equipment	17
Exterior Lights	17
Headlights	17
Rear Lights	17
Clearance Lights	17
Reflectors/Side Lights	17
Maintenance	17
Batteries	18
Maintenance	18
Electronics Audio/Video	19
Air Conditioning and Heating Systems	19
Fast Idle	19

Interior Operations and Maintenance	20
Walls and Ceilings	20
Maintenance	20
Flooring	20
Maintenance	20
Interior Luggage Racks (Optional)	21
Maintenance	21
Stanchion/Modesty Panel or Grab Rails	21
Maintenance	21
Seating and Components	22
Front Seats	22
Manual Seat	22
Power Seat	22
Passenger Rear Seats (Style is Optional)	23
Flip Seats	24
Fold-Away Seats	24
Armrests	24
Seat Recline/Side Release Handle	24
Side Slide Seats	24
Maintenance	24
Exterior Components and Maintenance	25
Washing	25
Waxing	26
Exterior Paint Care	26
Vinyl Graphics and Decals Care	26
Chrome, Stainless Steel and Aluminum Parts	26
Sealants/Caulk	26
Maintenance	26
Exterior Damages	

Body Panels, Roof and Cap	27
Maintenance	27
Exterior Damages	27
Windows	28
Emergency Exit (Egress) Windows:	28
Inspection and Maintenance of Emergency Windows	28
Passenger Windows (Non Egress)	29
Full View Curb Windows/Mor-View	29
Cockpit Window	29
Windshield	29
Window Maintenance	30
Exit Doors	31
Driver or Front Passenger Door (OEM)	31
Manual Bi-Fold Entry Door	31
Electric Bi-Fold Door	32
Lift Door	33
Rear Exit Doors	33
Rear Emergency Doors	34
Rear Door Interlock System (Optional)	34
Door Maintenance	35-36
Exterior Mirrors	37
Inspection and Maintenance	37
Emergency Vent/Hatch	38
Maintenance	38
Hood Latch/Engine Cover (Freightliner)	38
Maintenance	38
Under Carriage Luggage doors	38
Maintenance	38

Battery Box	39
Maintenance	39
Battery Door	39
Maintenance	39
Battery Tray	39
Maintenance	39
Battery Hold Down Straps	39
Maintenance	39
Underbody Areas	40
Maintenance	40
Air Ride Suspension (Optional)	40
Maintenance	40
OEM Air Suspension Reservoir (Optional)	40
Maintenance	40
Wheels	41
Replacements	41
Wheel Cover Insert (Optional)	41
Chevrolet 3500/4500, Ford E-350/E450	41
Freightliner, Chevrolet 5500, Ford E450	41
Tires	42
Care	42
Maintenance	42
Notes (a place to add your own notes as needed)	44

All rights reserved. Reproduction by any means, electronic or mechanical including photocopying, recording or by any information storage and retrieval system or translation in whole or part is not permitted without written authorization from Forest River Bus. Forest River Bus may change the contents without notice and without incurring obligation.

Introduction

Thank you for selecting your Forest River Bus. Your bus has been designed and constructed to reflect the Forest River Bus commitment which is to provide one of the safest, most reliable and comfortable means of transportation.

The bus is a combination of two major components, the Forest River Bus Body and the OEM Chassis, each built with a variety of options and components that were chosen to meet your transportation needs.

About This Manual

This manual has been prepared to serve as a reference document to acquaint you with the various operations and features, maintenance and service information, and most importantly, some general, as well as, specific information regarding the safe operation of the bus and its components.

The messages, instructions and information can help prevent personal injury to you, your passengers and others in or around the bus. We strongly recommend reading all of the manuals supplied and look through the bus to understand all labels, signs etc.

This manual is to be used in conjunction with/and as a supplement to your chassis manufacturer manual and all other accessories and component manuals.

Keep this manual, as well as all manuals in an easy to reach place so you can reference them easily. If you sell or trade the bus please keep the manuals with the vehicle so the new owner can use them.

Important Please Read Carefully

Every effort has been made to ensure that the information in this document is accurate at the time of preparation. However, this document is intended to serve only as a guide and cannot replace the first-hand information regulated by your individual State or the Federal requirements.

This manual does not address all items or situations that may arise and is not a substitute for proper driver operation, skill and or training. The exercise of care, common sense and good driving and working practices along with the complete knowledge of the bus operations are required for safe operation.

In the event of a conflict of information the Chassis and Component manuals information shall supersede any written information in this manual.

This document must be altered to address the compliance and operational needs of a specific carrier. This document, by itself, must **NOT** be used or accepted as meeting an individual carrier's State and Federal regulatory requirements. **The responsibility is still on the Owner/Driver to ensure that your programs meet the requirements of the law.**

Notice of the Following

- **Information in this Owner's Manual is not to be construed as a warranty term.** The descriptions, specifications and information provided in this publication provide no warranty expressed or implied.
- The terms of the Forest River Bus Warranty are set forth in your Forest River Bus Warranty document . If you do not have this document, please contact your dealer immediately.
- Your Forest River Bus may not have all or some of the equipment and or options described in this manual. Maintenance, service and operation, text, illustrations and specifications in this manual are based on information available at the time of printing.
- All descriptions and specifications provided in this manual were in effect at the time of printing and are subject to revision and/or changes without notice. Forest River Bus reserves the right to discontinue models or to change designs, options and specification at anytime without notice and without incurring obligation.
- All attempts have been made to ensure that the information provided in this manual is true and correct, However, we are not responsible for any errors, omissions or representations on any of these pages.

Unit Identification Numbers

FOREST RIVER BUS Production/Unit Number

This number is our body build number. This production number does not coincide with the Vehicle Identification Numbers (VIN) supplied by the OEM Chassis Manufacturer but is specific to the bus body.

The production number and date of production are printed on the Vehicle Safety Standard Certification Label located either on the driver door jamb or the drivers console near the cockpit window. It will be placed along with the Tire and Loading specification sticker. You will find further information regarding these labels on page 16 and 18.

Note: We are able to locate the bus body information using either the Forest River Bus production number and or the last eight (8) digits of the OEM chassis VIN number.

Vehicle Identification Number (VIN)

The VIN number is the identification number provided by the OEM chassis manufacturer.

It is the first number you will see on your Vehicle Safety Certification Label. It is also stamped in the upper driver side corner of the dash near the windshield.

Below are representations of the tag that is affixed to your vehicle upon completion of the build.

Note: When you are dealing directly with the chassis manufacturer they will only be able to identify your bus by their OEM VIN number and not the Forest River Bus production number.

Chassis Manufacturer
Vehicle Identification Number (VIN)
FOREST RIVER BUS
Production Number / Unit number



1GBJG41K791173397



GGF009998

GGF009998	MANUFACTURED BY / FABRIQUE PAR: FOREST RIVER, Inc VIN / NOU: 5NHBGGW399F009998 1GBJG41K8791173397 CS10121 GVM/R/PNBV: 5579 KG (12300 LB) TYPE/VIS: BUS/AUTOBUS DESIG. SEAT CAP./NOMBRE D'ESIGNE/ DE PLACES ASSISES 11X70kg=770 kg or 11X150lbs=1650 lbs	DATE: 8/28/2009 GGF009998	THIS VEHICLE CONFORMS TO ALL APPLICABLE U.S. FEDERAL MOTOR VEHICLE SAFETY STANDARDS IN EFFECT ON THE DATE OF MANUFACTURE SHOWN ABOVE.													
GGF009998	<table border="1" style="width: 100%; border-collapse: collapse;"> <thead> <tr> <th style="width: 20%;">CARGA/PNEU</th> <th style="width: 20%;">TIRE/PONEU</th> <th style="width: 20%;">RIBASQUANTE</th> <th style="width: 40%;">COLD INFL. PRE-SPECIFICS DE CONFL. ALTITUDE</th> </tr> </thead> <tbody> <tr> <td> TIRE/SEAT AVANT: 1950 KG 4300 LBS </td> <td rowspan="2">LT225/75R16E</td> <td rowspan="2">16 X 6.5J</td> <td> 448 KPa SINGLE DUAL 65 PSILP <input checked="" type="checkbox"/> <input type="checkbox"/> </td> </tr> <tr> <td> TIRE/SEAT ARRIERE: 0 KG 0 LBS </td> <td> 0 KPa SINGLE DUAL 0 PSILP <input checked="" type="checkbox"/> <input type="checkbox"/> </td> </tr> <tr> <td> TIRE/SEAT AVANT: 3901 KG 8600 LBS </td> <td rowspan="2">LT225/75R16E</td> <td rowspan="2">16 X 6.5J</td> <td> 448 KPa SINGLE DUAL 65 PSILP <input type="checkbox"/> <input checked="" type="checkbox"/> </td> </tr> </tbody> </table>	CARGA/PNEU	TIRE/PONEU	RIBASQUANTE	COLD INFL. PRE-SPECIFICS DE CONFL. ALTITUDE	TIRE/SEAT AVANT: 1950 KG 4300 LBS	LT225/75R16E	16 X 6.5J	448 KPa SINGLE DUAL 65 PSILP <input checked="" type="checkbox"/> <input type="checkbox"/>	TIRE/SEAT ARRIERE: 0 KG 0 LBS	0 KPa SINGLE DUAL 0 PSILP <input checked="" type="checkbox"/> <input type="checkbox"/>	TIRE/SEAT AVANT: 3901 KG 8600 LBS	LT225/75R16E	16 X 6.5J	448 KPa SINGLE DUAL 65 PSILP <input type="checkbox"/> <input checked="" type="checkbox"/>	THIS VEHICLE CONFORMS TO ALL APPLICABLE STANDARDS PRESCRIBED UNDER THE CANADIAN MOTOR VEHICLE SAFETY REGULATIONS IN EFFECT ON THE DATE OF MANUFACTURE.
CARGA/PNEU	TIRE/PONEU	RIBASQUANTE	COLD INFL. PRE-SPECIFICS DE CONFL. ALTITUDE													
TIRE/SEAT AVANT: 1950 KG 4300 LBS	LT225/75R16E	16 X 6.5J	448 KPa SINGLE DUAL 65 PSILP <input checked="" type="checkbox"/> <input type="checkbox"/>													
TIRE/SEAT ARRIERE: 0 KG 0 LBS			0 KPa SINGLE DUAL 0 PSILP <input checked="" type="checkbox"/> <input type="checkbox"/>													
TIRE/SEAT AVANT: 3901 KG 8600 LBS	LT225/75R16E	16 X 6.5J	448 KPa SINGLE DUAL 65 PSILP <input type="checkbox"/> <input checked="" type="checkbox"/>													
					CE VEHICULE EST CONFORME A TOUTES LES NORMES QUI UI SONT APPLICABLES EN VERTU DU REGLEMENT SUR LA SECURITE DES VEHICLES AUTOMOBILES DU CANADA EN VIGEUR A LA DATE DE SA FABRICATION.											

BUILT BY: Chevrolet

Safety Dangers and Precautions

It is vital that you review and follow all of the safety dangers and precautions listed throughout this manual, on safety labels applied throughout the vehicle, and those listed in the chassis and other component manuals.

As an owner/driver you are responsible for the safety of your passengers and the people around your vehicle.

Safety Danger Symbols and Labels

Throughout this manual we call attention to specific safety issues and hazards. Observe all safety danger operating parameters listed in this manual, as well as signs or labels that may be mounted throughout the bus.

The following boxes are used to tell you about items that could cause you or other people harm and/or result in death if the information or instructions are ignored.

Always pay special attention to this information.

DANGER

Whenever you see this DANGER box, exercise caution and follow the instructions provided. Failure to do so could lead serious injury or death.

WARNING

Whenever you see this exercise caution and follow the instructions provided. Failure to do so could possibly lead to injuries and or death.

CAUTION

Whenever you see this exercise caution and follow the instructions provided. Failure to do so could lead to injuries.

NOTICE Information

The following blue topped box with the word “NOTICE” is used to tell you about items that could cause harm to your bus and or its components if the information or instructions are ignored.

Failure to follow instructions provided in this manual as well as the chassis and component manuals, could result in costly repairs that will not be covered under warranty.

NOTICE

Failure to regard the information and instructions provided in this manual and the ones listed in the chassis and component manuals could result in costly repairs and possibly void portions of your warranty.

Alterations or Nonstandard Components

The safety and/or performance of your vehicle could be adversely affected by the installation of nonstandard components or by making modifications or alterations to the current systems in your vehicle.

Please contact your Selling Dealer, your Chassis Manufacturer or FOREST RIVER BUS before making any alterations or modifications or adding nonstandard parts and components to the vehicle or the chassis.

Failure to do this could put your passengers in danger as well as void portions of your warranty.

WARNING

Alterations, modifications, and/or installation of nonstandard items can adversely affect the safety features and systems of your vehicle. Before making modification, alterations, or before installing nonstandard parts and components contact the chassis manufacturer, your selling dealer or Forest River Bus to ensure you are staying within the proper vehicle safety standards.

NOTICE

Unauthorized alterations and or installing nonstandard parts and components can alter and or void portions of your warranty.

Reporting Safety Defects

If you believe your vehicle has a safety defect that could cause a crash or could lead to serious injury or death, you should immediately inform the National Highway Traffic Safety Administration (NHTSA) in addition to notifying Forest River Bus.

If NHTSA receives similar complaints, it may open an investigation and if they find that a safety defect exists in a group of vehicles, they may order a recall and remedy campaign. However, NHTSA cannot become involved in individual problems between you and your dealer or Forest River Bus.

National Highway Traffic Safety Administration Contact Information

To contact NHTSA you may either call the Auto Safety Hotline toll free at 1-888-327-4236 (or TTY 1-800-424-9153) or go to www.safercar.gov; or write to Administrator NHTSA, U.S. Department of Transportation, 400 Seventh Street SW, Washington, D.C. 20590.

You can also obtain other information about Motor Vehicle Safety from the website.

FOREST RIVER BUS Contact Information

To notify Forest River Bus in regards to the safety defect please call us at 1-800-348-7440 or 574-264-3112 press zero (0) for the operator and ask for Customer Service .

If you would prefer to write a letter the address is Forest River Bus Customer Service, 2372 Century Driver, Goshen, IN 46528 Attn: Customer Service Department

Vehicle Weight and Loading Information and Restrictions

Your Forest River Bus is designed to carry loads that are specified by the chassis manufacturer which allows for the reasonable weight of passengers as well as their luggage.

It is very important that you know the various weight limits/ratings of your bus. The driving ability and handling for the bus could be greatly altered or affected if your bus is overloaded.

Vehicle Safety Standard Certification Labels

The weight and loading restrictions are specified by the chassis manufacturer. These specifications are posted on the Vehicle Safety Standard Certification labels. Depending on the make and the model of your bus the labels will be either affixed on the driver's door or on the driver's console.

These loads are defined by the Gross Axle Weight Rating (GAWR). The GAWR is the value of the load carrying capacity of a single axle system. It is measured by the tire/ground interface, plus the Gross Vehicle Weight Rating (GVWR), which is the maximum permissible load/weight of the bus.

The labels provides the following information (see location of information on tag below).

- Original Equipment Manufacturer of the Chassis Vehicle Identification Number (OEM VIN)
- Name of the body manufacturer (MFG. BY)
- Forest River Bus Production Number
- Date the Forest River Bus body was manufactured (DATE OF MFG.)
- Certification Statement
- Vehicle type
- Tire Information
- Weight and Loading Restrictions:

Gross Vehicle Weight Rating (GVWR) This is the gross rated weight capacity of your vehicle.

Gross Axle Weight Rating (GAWR Front) This is the rated weight capacity of the front axle.

Gross Axle Weight Rating (GAWR Rear) This is the rated weight capacity of the rear axle.

Example of Label shown is not to scale

The label contains the following information:

- OEM VIN:** 1FDFF45L58DA78600
- FOREST RIVER BUS PRODUCTION #:** GUF009855
- DATE OF MFG:** 11/11/2009
- CERTIFICATION STATEMENT:** THIS VEHICLE CONFORMS TO ALL APPLICABLE U.S. FEDERAL MOTOR VEHICLE SAFETY STANDARDS IN EFFECT ON THE DATE OF MANUFACTURE SHOWN ABOVE.
- VEHICLE TYPE:** BUS/AUTOBUS
- GVWR:** 6373 KG (14050 LB)
- GVWR FRONT:** 3288 KG (7280 LB)
- TIRE INFORMATION:** LT 225/75R16E, 16X6.0K, 515 HP SINGLE DUAL, 75 PMA PC
- GVWR REAR:** 4308 KG (9500 LB)

CHASSIS	TIRE/TYPE	AXLE/TYPE	COLL. WT. FR. TRANSFER	COMPL. A FROD
FRONT AXLE 2288 KG (5000 LB)	LT 225/75R16E	16X6.0K	515 HP SINGLE DUAL 75 PMA PC	<input checked="" type="checkbox"/> <input type="checkbox"/>
INTERMEDIATE AXLE 0 KG (0 LB)			0 HP SINGLE DUAL 0 PMA PC	<input type="checkbox"/> <input checked="" type="checkbox"/>
REAR AXLE 4308 KG (9500 LB)	LT 225/75R16E	16X6.0K	552 HP SINGLE DUAL 80 PMA PC	<input type="checkbox"/> <input checked="" type="checkbox"/>

INSTR. VEH. MFG. BY: Ford

Loading Procedures

The distribution of weight in your bus is very important. Having too much weight on one side or the other or having too much weight in the rear compared to the front axle can adversely affect the handling of your vehicle and in some cases result in overloading the tires or axle components. Always use care to assure that you maintain as much of an equal balance as possible when loading your vehicle.

Please note that a loaded bus can handle differently than an unloaded vehicle. When you are driving a heavily loaded vehicle take extra precautions, such as reducing speeds and/or increasing your stopping distance.

Avoid stacking heavier items in the overhead above a passenger seat. Whenever possible secure loose items; as passenger luggage, your tools, equipment or anything else that you may put into the vehicle can become airborne in the case of a sudden stop, turn, or in a crash.

Weighing Procedures

Any loaded bus can have the potential of being overloaded and it may be necessary to remove some of the extra luggage or redistribute items to make the load even. The weight of the empty vehicle will vary based on the equipment and options installed on your bus.

An overloaded vehicle can alter the handling ability or cause the tires to overheat or air-out resulting in an accident. Overloading can also cause parts to break and/or shorten the life of the vehicle.

It is your responsibility to weigh the bus from time to time to make sure you are staying within the weight limitations specific to your bus. It is important to weigh your bus at a location that can provide axle-end specific weights. You should not expect to measure equal loads at both ends of the same axle. Your floor plan and the component locations can vary the distribution of the weight.

It is very important that you read the chassis owner's manual it will provide additional information on the complete procedures for weighing and loading your vehicle.

DANGER

Exceeding the Vehicle Safety Standard Certifications Label weight rating limits (GVWR, GAWR) could result in substandard vehicle handling which could cause a loss of control and could lead to serious injury or death.

DANGER

Overloading the bus can cause your tires to overheat resulting in too much friction and you could have a blow-out which could lead to serious injury or death.

DANGER

Do not modify your vehicle by adding additional equipment or racks to carry additional cargo. This could cause you to exceed your weight limit and/or place the vehicle out of balance, altering the handling of the vehicle, causing a loss of control, which could result in serious injury or death.

NOTICE

Overloading your vehicle can cause poor performance, engine, transmission, or other structured damage. Parts and components damaged by an overloaded vehicle may not be covered by your warranty.

Tire and Rim Certification Label

The tires and rims supplied are designed to meet the Federal specifications and to provide reliable and safe transportation. These labels are either located on the drivers door or in the drivers console area.

The label provides the following information (see location of information on tag below).

- Original Equipment Manufacturer of the Chassis Vehicle Identification Number (OEM VIN)
- Vehicle ID (VIN #)
- Forest River Bus #
- Combine Weight of occupants and cargo that should not be exceeded (two areas)
- Seat belt supplied
- Caution Information regarding water and trailer towing (if applies)
- Seating capacity
- Tire and Rim information
- PSI information

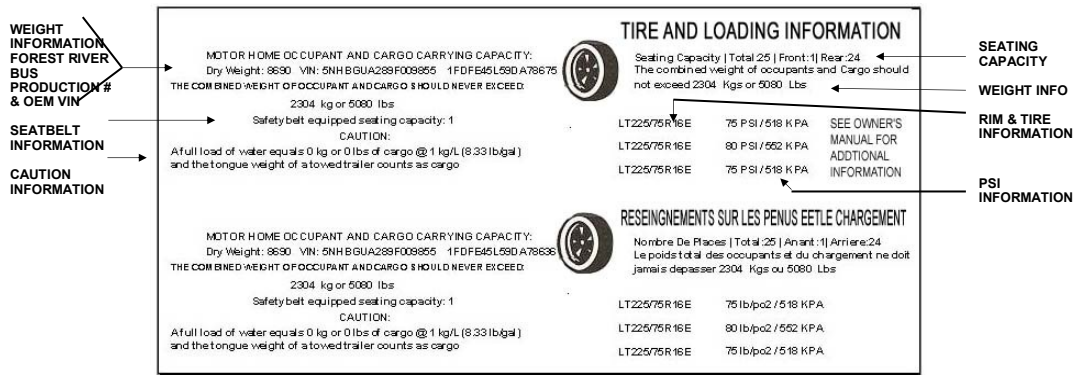

Example of Label not to scale

Tire Pressure Information

Proper tire inflations not only helps ensure a safe trip it greatly improves tire tread life, tire wear, fuel mileage, and handling of the unit. Inflate the tire pressures to specification listed on the Tire and Rim Certification Label.

Under inflated or over inflated tires can not only result in damaging the tire but can also cause a handling problem putting you and others in danger. All tires on an axle should carry the same inflation pressure and the inflation pressure should be adjusted to handle the maximum tire load,

Please review the Chassis and Tire Manufacturers manuals for information in regards to tire and rim safety operations and maintenance.

DANGER

Do not run with over inflated or under inflated tires either of these conditions can result in poor handling or the loss of control resulting in an accident which could lead to serious injury or death

- Over inflated tires are more prone to be punctured, cut, or broken in a sudden impact (such as a pot hole) which can result in loosing control of the vehicle.
- Under inflated tires are prone to the tire overheating resulting in sudden air loss or catching on fire and or the loss on control of the vehicle.

NOTICE

Damages to your tires and or wheels due to the tires being under or over inflated can result in voiding your warranty. Review the tire manufactures warranty for complete information.

Be Prepared for Emergencies

Potential emergencies are always an issue when you are dealing with passengers, traffic, weather, and road conditions. We want to help you as a driver achieve the highest level of safety not only for your passengers but also for the people around and near the vehicle.

It is very important to review this manual, the chassis manual, and all of the component manuals supplied to ensure you understand all of the safety equipment.

Emergency Preparation

Emergencies can happen anytime, anywhere, and when they strike, you may not have much time to react. Emergency planning may not prevent emergencies, but it can help protect lives. By knowing where the safety equipment is located and understanding the operations of the equipment supplied you will be helping to ensure a safe trip.

Escape Routes

It is the driver's responsibility to make sure everyone is familiar with and understands the escape routes of the bus. It is also their responsibility to make sure the exits are clearly marked, the components are functional and the passageways are not obstructed in any way.

The number of emergency exits depend on the type, model, and size of your bus, along with the options selected. All models have the following emergency exits; at least one egress window on each side of the bus and one of the following: a rear egress window, rear emergency door or a roof hatch. Your unit may have additional egress windows or a combination of windows, doors and/or a roof hatch. Please check through your bus to locate all of the emergency exits available to you and your passengers.

Emergency Exits

Emergency exits must be clearly identified by the words "EMERGENCY EXIT" with the operating instructions written on or close to each exit feature.

Note: If the decals and or signs have been removed please contact Forest River Bus Customer Service to obtain new decals.

Before each trip inspect Emergency Exits

Emergency exits can be a door, an egress window, and/or a hatch. Please review the "Exterior Components and Maintenance" section for information on the use and care of the Emergency Exit Doors, Windows and Hatch's .

- Check to see that all emergency exits are clearly marked with a proper "Emergency Exit" sign or label and that all instructions are intact for each component.
- Check that of all emergency exits are in proper working order.
- Check that the passageways are not obstructed..
- Inspect all hardware such as latches, handles, and brackets to ensure they are not loose, broken, or damaged.
- Check all windows and doors to ensure they do not have loose, cracked, or damaged glass.



WARNING

Unless all "Emergency Exits" are clearly marked, working properly, and the instructions are in tact do not carry passengers. The inability to find, access, and/or operate the emergency exits will put your passengers in great danger if an accident occurs. The result of injuries can be much worse and/or result in death if an evacuation is necessary and the escape routes are altered or prohibited.

Fire Extinguishers (Optional Equipment)

The operation of a fire extinguisher is simple however it must be properly handled in times of emergency.

Be sure you know where the Fire Extinguisher is located and how it operates before you start your trip.

It is very important that you read the manufacturers instructions on the label and their sheets or manuals for operation and maintenance of a Fire Extinguisher before using the bus as it is too late when you are in an emergency.

The fire extinguisher can be located in the cab in front of the wall, next to the entrance door or behind or next to the driver's seat.

Note: location may differ due to customer requests and/or options.

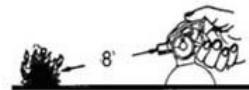

Be at least 8' away from Fire.
Make sure your back is to an unobstructed escape route.

Fire Extinguishers are Recommended for SMALL FIRES only.

If any portion of a bus is on fire safely stop the bus and evacuate immediately.

Passengers should move at least 100 feet or more from the bus and remain there until it is safe.

If you chose to fight a fire it is recommended that you stand at least 8 feet back from the fire make sure your back is to an unobstructed escape route. Always follow the fire extinguisher manufacturer's instructions.



WARNING

Failure to properly evacuate the bus or follow the manufacturers instructions and/or information for the fire extinguisher could result in serious injury or death.

Fire Prevention Suggestions:

- DO NOT overload electrical wiring.
- DO NOT replace a fuse with one of a higher amp rating.
- DO NOT store flammable liquids inside the vehicle.
- DO NOT park over papers, leaves, dry grass or other things that can be ignited if touched by hot exhaust parts under your vehicle

Reflector Kits (Optional Equipment)

Triangles can save lives if there is ever a roadside emergency. Using the triangles allows drivers to better see you on the side of the road well ahead of time, allowing them to slow down and possibly change lanes.

If your unit was not provided with the Triangles we strongly suggest you purchase a set for your unit.

The Forest River Bus optioned reflectors will unfold and lock into the shape of a triangle. The placement of the reflectors will depend on the traffic location and the weather conditions.

- It is suggested that you place one reflector 10 feet from the driver side rear of the bus closest to the white line by your vehicle.
- Place the second one 100 feet back placing both closest to the white line by your vehicle.
- Place the third reflector 200 feet in front of the driver side near the white line to show on coming traffic that vehicles coming toward them may need to move left to pass.

Fuel Tank Safety

Always use the recommended fuel listed in your Chassis manual. Any type of fuel can be dangerous if misused. Mixing gasoline with diesel fuel can cause an explosion. The wrong type of fuel will also cause damage to the engines emission system.

When dealing with fuel it is important that you take steps to protect you, your passengers and the people around the vehicle .

Improper handling of fuel can result in a fire or an explosion . While high levels of concentrated gasoline vapors are potentially dangerous even the lower gasoline vapors can be harmful to human health.

To ensure safe handling before and while fueling your bus please follow the suggestions below:

- Turn off your engine before fueling.
- Never leave your vehicle unattended while the pump is running.
- Do not smoke or light matches or lighters.
- Try not to breathe the fumes by standing upwind of the nozzle while refueling.
- Do not top off your tank. Even little drips that fall onto the pavement can contaminate soil, groundwater, or surface water.

It is very important that you review your Chassis Owners Manual in regards to fuel and fueling information. Pay special attention to the safety information and procedures.

WARNING

Improper handling of fuel could result in serious injury or death caused by fire, explosion, or asphyxiation. Refer to your chassis manuals for fuel information regarding the proper fuel to use in your vehicle as well as all of the proper procedures and safety information.

NOTICE

Using the wrong fuel in your vehicle can cause damage to the engines emission system. This damage could result in a costly repair that would not be covered under warranty.

Other Safety Tips

Again we ask that you review this manual, the chassis owner's manual, components and all other information supplied concerning the chassis operations and features. Pay special attention to the safety dangers and cautions.

Below are a few other tips in regards to safety.

- Do not overload the electrical system or alter any wiring without expressed written permission of the manufacturer.
- Never disconnect safety devices installed on your bus.
- Always use proper procedures when restraining wheelchairs, review the manuals provided to understand the proper installation and restraint system for your vehicle.
- If you have passengers who require special loading and unloading procedures, be sure you know the proper way to move, secure and respond to the special needs of your passengers.
- Steps, running boards or ramps may become slippery during wet, snowy or icy conditions. Be sure to keep the steps clear of debris and/or ice. Make customers aware of the potential hazards such as slippery steps or ramp when entering and exiting the bus.
- Never place or carry portable fuel burning equipment, including wood and charcoal grills/stoves inside the bus. This type of equipment may cause asphyxiation or create a fire hazard.
- Review the maintenance schedule required for all safety items to ensure they have been properly maintained.

Be Responsible for Safe Transportation

Our goal is to help you as a driver and owner achieve the highest practical level of safety not only for your passengers but also for the people around and near the vehicle.

It is the Owner's/Driver's responsibility to use the bus for its intended design purpose. It is also the owner's/driver's responsibility to observe and comply with the proper operating practices and safety regulations that are in the supplied manuals as well as comply with local, state and federal laws.

It is the Driver's responsibility to understand the operation of the complete bus. Failure to follow the proper procedures could affect the performance on the bus and/or affect the safety of the passengers. It is important that you familiarize yourself with all Forest River Bus body features along with the chassis and other components.

Pay special attention to the safety equipment supplied on the bus. Review all labels and instructions so you will know what to do in the case of an accident. Review this manual along with the chassis and components manuals to help ensure you have a clear understanding of your Forest River Bus.

A bus should not be driven unless the driver has the appropriate license or permit to operate it.

WARNING

Failure to use the bus for its intended design purposes and/or failure to understand the complete driving operations, instruments, and controls of this bus, could lead to an accident resulting in serious injury or death.

NOTICE

Failure to use the bus for its intended design purposes and/or failure to understand the complete driving operations, instruments, and controls of this bus, could lead to an accident causing damage to the vehicle and/or could void areas of your warranties.

Helpful Driving Tip

Plan your trip and prepare as much as you can before you leave.

- Drive with consideration of others on the highway, observing speed and safety regulations.
- Observe proper vehicle speeds when ascending or descending hills and always operate in the proper transmission range.
- Allow for the length and width of the vehicle and for the extra room when turning a corner or changing lanes.
- Allow a safe distance in which to stop your vehicle, never follow another vehicle too close and avoid sudden maneuvers when passing another vehicle.
- Check rear view mirrors and signal lane change before passing. Check the side mirrors often. Learn to use the view of the roadway behind through the side-mirrors.
- Allow for the extra height of your vehicle. Check the clearances for any overhead obstructions such as bridges, branches, garage doors, overhangs, low wires etc.
- When backing into congested areas, have someone outside the bus check to be sure the way is clear before putting the bus in motion.
- Stay Alert. Don't drive for long periods of time without stopping. On long trips allow plenty of time to stop for rest.

Pre-Travel Inspections

Performing a pre-trip inspection can not only ensure a safer trip it can help keep the maintenance costs down. Any item no matter how small if neglected could result in a chain affect causing other items on your bus to fail. This could affect the overall performance and safety of your bus and could result in costly repairs and/or lengthy down times.

The following information is not intended to be the complete list of all possible services that need to be performed on a regular basis, it is important that you review all of the other manuals and information supplied with your bus.

Our daily inspection suggestions may be considered to be excessive but the shorter time intervals between inspections and service is preferable. This list is not to be construed as a complete list of all possible items that should be checked daily.

This is a small sample please review the chassis manual for operation and checks that need to be inspected

Fluid Levels	Check for proper fluid levels such as engine oil, transmission, power steering, brake fluid as specified per the specific manufacturers information manuals.
Cooling System	Check the cooling system. When needed add the proper coolant as recommended by the OEM manufacturer. <u>Note:</u> If coolant level goes below sensor on some models it can go into engine protection mode. If coolant is neglected and is not filled to the proper levels it can cause air pockets and bus will loose heat in rear systems.
Headlights	Check that the high and low beams are operating and are properly adjusted.
Warning Lights	Check that the front and back clearance, hazard, back-up lights and brake lights are properly operating.
Turn Signals	Check that the front and back signals are operating properly .
Mirrors	Inspect to ensure they are secure, unobstructed, and properly adjusted for the driver.
Egress Windows	Check to ensure the windows are closed tightly and properly latched and damage free.
Windows/Windshield	Check the windows to ensure they are clean and damage free.
Flooring and Steps	Visually inspect that the floor is smooth and intact and nothing is in the aisle or step areas.
Entry Doors	Check that the side passenger entry door, lift doors & rear door all open and close easily and the latches/catches are working properly.
Emergency Exits	Check operations for doors, labels and instructions are present and alarms and or the warning devises are working properly. Make sure the paths to the exits are free and clear.
Body Components	Check for damages that could inhibit driving the unit for example; if the skirts are damaged check to be sure they are not rubbing or restricting the tires in any way.
Batteries	Inspect that the batteries are fully charged and the cables are secure and properly connected and they are not damaged.
Battery box/tray	Check that the tray is pushed in securely and the battery box door is latched.
Luggage Bay Doors	Check that the hardware handles and attachments are in proper working order and doors are closed tightly and locked.
Tires	All tires should be visibly inspected for inflation and tread wear, refer to the tire manufacturers information for proper inflation levels and tread/wear information.
Wheels	Check all lug nuts for proper tightness or excessive wear.
Exhaust	Visually inspect the exhaust to ensure it is not hanging down or damaged.
Fuel Cap	Check to ensure the cap is secured in place.

Driver Seat	Check complete operations of the seat.
Driver Seat belt	Check operation of the drivers seat belt.
Brakes	Brakes should be checked by putting the vehicle in gear without acceleration and applying the brakes. Check the foot pedal and parking brake operation.
Transmission Selector	Vehicle should be capable of being shifted into any gear
Steering Wheel	Verify a full range of motion and ability to effectively turn the front wheels.
Wiper System	Check the operation of the wipers and washers. Make sure the wiper blades are performing properly
Windshield Wipers	Wipers work at all settings and wiper fluid pump is working.
Horn	Horn is operating properly
Air and heat Systems	Check the operations of the heating or air conditioning, defrosters and fans
Gauges and Indicators	All gauges and indicators should be visually inspected to make sure that they are operational.
PA System	Check the operation if option available.
Radio Two Way	If the vehicle is equipped with a two way radio, a radio check should be conducted with your dispatch department.
Step and Flooring	The floor is smooth and intact and nothing in the aisle or step areas
Luggage	Interior luggage is secure and not overloaded over anyone's seat.
Manual Door operation	Check that manual door tri-pod handles are moving freely and the door is secure when shut.
Electric Door operations	Work properly when pushing the button on the dash including full range when opening and closing securely
Emergency Equipment	Check all emergency equipment as previously explained under the "Be Prepared for Emergencies" section in this manual

Specialized Components

Lift Operation All wheelchair lifts be checked for proper operations. Check that the proper securements are available and is not damaged.

Note: To keep the unit in proper working order the lift should be cycled daily.

Seat Belts

Buckle Up

Seat belts are designed to secure a person in the vehicle helping to reduce the chance of injury or the amount of injury resulting from accidents or sudden stops. You never know if you will be involved in an accident or crash so please make sure that you and all your passengers use the three-point and/or lap seat belts while your vehicle is in motion.

NHTSA Seat Belt Use Information

The following seat belt use information was derived by the website using the following link: National Highway Traffic Seat belt use:

www.nhtsa.gov/staticfiles/nti/teen-drivers/pdf/seatbeltuse.pdf

Using Seat Belts (as per NHTSA Web Site)

Before you drive away, always fasten your seat belt and make sure all your passengers are using seat belts or child restraints. Also, remember to lock the vehicle's doors and turn on the childproof locks if children are in the vehicle.

Studies have shown that if you are in a crash while using seat belts, your chances of being hurt or killed are greatly reduced. Seat belts will move with you and lock up if a crash occurs. They keep you from being thrown from the vehicle and against parts inside of your vehicle. In addition to protecting you from injury as a driver, seat belts help you keep control of the vehicle. If you are struck from the side or make a quick turn, the force could push you sideways and therefore you cannot steer the vehicle if you are not behind the wheel. In many states it is illegal to drive or to be a front-seat passenger, without wearing seat belts. Seatbelts may be required under graduated driver licensing for drivers or all occupants of the vehicle.

Wear a seat belt all the time, not just on long trips or high-speed highways. More than half of the crashes that cause injury or death happen at speeds less than 40 mph and within 25 miles from home.

It is important to wear the seat belt correctly.

- A shoulder harness is worn across the shoulder and chest with minimal, if any slack. The shoulder harness should not be worn under the arm or behind the back. Wearing the harness the wrong way could cause serious internal injuries in a crash.
- The lap belt should be adjusted so that it is snug and lies low across your hips after fastening. If you have an automatic shoulder belt, be sure to buckle your lap belt as well. Otherwise, in a collision you could slide out of the belt and be hurt or killed.
- You should be seated upright with your back against the seat and feet on the floor. Improper seating positions, such as slouching or resting one's feet on the dashboard can result in reduced effectiveness of the vehicle's restraint system and possibly result in injury.
- Seat belts should be worn even if the vehicle is equipped with air bags. While air bags are good protection against hitting the steering wheel, dashboard or windshield, they do not protect you if you are hit from the side or rear or if the vehicle rolls over. In addition, an air bag will not keep you behind the wheel in these situations.
- The law requires that all children under the age of 12 must be secured in the rear seat and wear appropriate seat restraints while the vehicle is in motion.



Correct



Incorrect

Source: ADTSEA

Maintenance

- Daily inspect the complete safety belts system such as the buckles, latch plates, retractors, and the anchorage portions, to ensure they are not compromised, loose, damaged and/or missing any parts.
- Inspect the belts to ensure they are not torn or frayed and replace if found in these conditions
- Repair/replace any damaged or compromised part such as the ones listed below.

Proper Preventative Maintenance and Care

We all know that preventative maintenance can add years to the life of your vehicle, but, more importantly, it can save lives. The safety and performance of your vehicle can be greatly affected if the vehicle and its components are not properly maintained.

Negligence and/the lack of maintenance of a vehicle or its components can more than likely increase the possibilities for injuries in the event of an accident.

Not only can proper maintenance increase the reliability of the vehicle it can help prevent huge cost in down time and costly repairs. Neglect of any minor repair can lead to thousands of dollars of work as time goes by. Throughout this manual we have included some preventative maintenance and inspection information, but again it is important that you review all of the other manuals supplied with your bus.

Important Note: The preventative maintenance and service information in this manual is not to be construed as a complete list of all possible items that should be performed or the intervals that they should be performed in. Review your chassis and, other component manuals.

Service and Maintenance Programs

We suggest that you contact your local OEM (Chassis Manufacturer) dealer to discuss the type of service and maintenance program specific to your unit.

Discuss the type of service you provide to your customers. For example, is your unit going to run at a continual slow speed with several stops or is it a unit that is used mainly on the highways with just a few stops? Is your service a daily service or a 24 hour service? What is the average miles or the basic engine hours? This type of information can help them develop the best schedule that fits the needs for your chassis, engine, transmission, tires etc.

The operation of the service and maintenance needed can vary from the recommended schedules and timetables due to a range of factors including traffic, weather, and passenger loading and operating/driver behavior.

An example of this would be the fact that the colder weather climates road salt and other road chemicals or sand are particularly hard on the exterior and underbody of a unit. For units in these types of environments you would need to pay special attention to the under carriage and seams of the unit more often than a bus that is not exposed to these elements.

Failure to perform the proper scheduled maintenance may result in excluding portions of your vehicle from warranty coverage and may reduce the performance, safety, reliability and/or the resale value of your vehicle.

WARNING

The safety or performance of your vehicle can be greatly affected if the vehicle and its components are not properly maintained. Failure to provide proper maintenance could alter the performance of a part or component and/or cause it to fail. The consequences of a faulty or failed part or component could result in injury or death.

NOTICE

Failure to provide proper maintenance for your vehicle could alter the performance and/or could cause something to failure. One failed part could result in a chain affect causing other items on your bus to fail resulting in expensive repairs. Lack of maintenance and care could also result in voiding certain portions of your warranty.

Electrical System

Your bus utilizes both the Original Manufacturer's Chassis electrical system which runs the automotive portion of the unit and the Forest River Bus system that provides the power for the conversion portion of the unit.

Forest River Bus* Electrical Panel

*Non-Applicable to Elkhart Coach

Your unit is equipped with a Programmable Relay Power Center (PRPC). This system interfaces with the chassis electrical system via the OBDII, or J1939 diagnostic ports which are located just under the dashboard to the left of the steering column. The system uses real-time chassis data to control loads and connects electronic modules through the overall vehicle network. It shares information between modules and centralizes and improves diagnostic capabilities.

Important Note: Forest River Bus utilizes the OBD II (J1939 when applicable) port on this chassis. If you are adding your own electrical equipment that will be connected into this port, there could be adverse effects to the electrical system, including but not limited to the functionality of the lift ADA interlock system. **Prior to adding equipment, please contact Forest River Bus** (1-800-348-7440) to determine compatibility and/or re-programming requirements

Due to the complexity of the system and the interaction with the chassis system we suggest that only a certified technician performs any service work that may be needed. A certified service technician should always call Forest River Bus Customer Service (1-800-348-7440) for assistance before they perform any service work on the unit.

The location of the electrical panel is housed in the compartment located in the b-pillar above the driver's seat.

Note: The circuitry and wiring for the vehicle's functions are located on the inside of the electrical box door.

Replacing a Fuse

When checking the fuses on the PRPC, a RED LED light will illuminate on the PRPC if A) a fuse is blown, or B) a fuse is missing. Always replace a bad fuse with a new one of identical size and rating. Please refer to the Electrical Control Panel schematic on the inside of the electrical box door for the correct fuse size.

WARNING

Never replace a fuse with circuit breakers or fuses with a higher amperage than originally installed. As well as never replace any fuse or circuit breaker with automatic resetting fuses, or circuit breakers. Over-fusing, or installing auto reset fuses/circuit breakers may cause the circuit wires to get hot, and start a fire which could result in serious injury or death.

Maintenance

We suggest that during any of the regular scheduled maintenance and/or at least every 12,000 miles, the following procedures are performed.

Check wiring connections and circuits to ensure they have not become loose or broken. Disconnect the battery before performing any electrical work.

- Be sure to Coat all exterior connections with battery anti corrosion spray. The main focus being the battery terminals in the engine area, battery box (if applicable), or the frame rail battery, and all Forest River Bus installed circuit breakers. Forest River Bus recommends using NOCO A202S NCP-2 Battery Corrosion Preventative

Spray.

- Check that ground cables are clean, undamaged, and tight. If necessary, disconnect them and clean the mating surfaces with a soda solution. Then, connect them securely, and recoat with anti corrosion spray.

WARNING

Before anyone begins any electrical work make sure to disconnect all batteries. Always remove all battery ground straps first and replace last to prevent accidental arcing. Failure to do this could result in serious injury or death.

Forest River Bus Switches, Controls, and Indicator Lights

You may have a variety of toggle switch's, indicator lights and A/C controls. The type of switches and controls used in your unit are dependent on the make and model of your vehicle as well as the option content. The switches and or controls can be located on the dash, the drivers overhead area or left of the driver on the door and/or panel.

The following pages will explain many of the basic information for the different systems that may be on your bus.

Chassis Manufacturer Lights, Signals and Equipment.

The chassis circuits supply the power for the exterior lighting such as headlights, brake lights, clearance lights as well as the interior dashboard light and gauges including the horn, turn signals, and headlights. They are also used to power the engine and transmission computers, dash lighting, and the engine starting system and other chassis items.

Exterior Lights

These lights will be located on the front, sides, and rear of your bus . While some of the exterior lights may be provided by the Chassis manufacturer, other lights may be provided by utilizing the Forest River Bus electrical system in conjunction with a 12-volt electrical system.

For everyone's safety it is imperative that all lights such as, emergency directional, hazard ,clearance, marker and all other identifying lights, are in working order. These lights help others recognize the vehicle's presence, position, size, direction of travel, as well as the driver's intentions regarding direction and lane changes.

Headlights

Provided by the Chassis manufacturer with the chassis.

Rear lights

Your unit is equipped with two red tail lights, two amber tail lights, two white back up lights and one white tag light.

These lights are LED and provided by Forest River Bus.

Clearance lights

Your unit is equipped with five amber lights in the front cap and 7 red lights in the rear cap. These lights are LED and will illuminate when the engine is started.

Reflectors/Side lights

Your unit will be equipped with front and rear side marker devices.

Maintenance

- Review the Chassis Owners manual for information on circuits and wiring, including headlights, turn signals, dash board and drivers area lights, as well as the factory fuse panel.
- Inspect all lights and reflectors daily. Note: It is recommended to have someone outside the bus check the operation of each, as someone inside activates each function. If a helper is not available to check the lights activate the particular function from the inside and go outside the bus to view.
- Replace any blown or damaged bulbs and/or fixtures and missing reflectors immediately.
- Check at least every 6 months for frayed or damaged wires and or loose connections.
- Clean the lenses and reflectors with window cleaner and /or a nonabrasive detergent.

WARNING

Driving without the proper warning, marker, clearance, hazard and directional lights, reflectors, etc. is dangerous. Lack of signals or lights could result in serious injury or death.

Batteries

You must maintain your batteries to ensure that your batteries perform their best and last the longest. Batteries can fail due to age, but can also fail due to the lack of maintenance or failure to observe the proper charging procedures. Batteries can't pass power to the electrical system if their connections are all corroded. You will need to check and clean these connections regularly as part of a scheduled maintenance cycle

Maintenance

It is very important that you read the manufacturer's instructions for operating, maintaining and charging of each of the batteries.

- Check to ensure the batteries are mounted securely. Excessive vibration can cause early battery failure.
- Keep the battery clean. Corroded terminals make poor contact. Battery sulfating occurs when the battery has been standing in a discharged condition over a long period of time or when the battery has been operated continually in a state of partial discharge.
- Check the outside condition of the battery. Look for cracks in the case or vent plugs. If the case is cracked, the battery must be replaced. If the vent plugs are cracked, they must be replaced.
- Battery Terminals: Monthly check battery terminals for dirt and corrosion (green powder foam). Corrosion can alter the performance and destroy the battery. Most corrosion can be removed by using a bristle brush soaked in baking soda, rinse with water or as directed in the battery manual.
- Battery Charging
 - Monthly check battery for charge, as per the manufacturer's instructions. It may be best to take your unit to a trained dealer technician and have them use the proper diagnostic equipment to test the battery.
 - Before charging any battery, inspect the battery connections for loose or damaged connectors and the battery terminals for frayed conductors. Make sure they are both clean and securely fastened to the battery post.
 - Watch for over-charging. Three ways to spot over-charging are:
 1. Active material on the vent cap (heavy deposit of black lead-like material on underside of the vent cap).
 2. Excessive use of water.
 3. By testing voltage regulator output.

Battery replacement: When a battery needs to be replaced, make sure to replace it with a battery of the same characteristics as the original equipment.

WARNING

- Before performing any maintenance or working near the battery area protect yourself from harm by disconnecting the cables using the procedure explained in your battery manual.
- Always shield your eyes when working near batteries. Batteries can explode.
- Do not smoke or expose battery to electric spark or flame
- When charging or discharging, batteries generate hydrogen. Hydrogen and air is a very explosive mixture.
- Do not short across the battery terminals. The spark could ignite the gases. Do not wear metal jewelry or a watch when working on a battery.
- Battery electrolyte is a corrosive, poisonous sulfuric acid. Avoid contact with skin, eyes, clothing or any painted surface.

Electronics Audio/Video

The features and components in your unit are dependent on the model and the options you chose.

Due to the variety of electronics, models and styles available, we refer you to your individual components manufacturer's manual for the operating instructions, the maintenance, troubleshooting, service and warranty information.

Most of the information will be found in the blue bag that was delivered with your unit. The bag contains additional miscellaneous and safety information. It is important that you read the safety information in the manufacturer's owners manual for each component provided in your bus.

Air Conditioning and Heating Systems

Air conditioning and heating systems come in a variety of configurations designed to keep everyone comfortable. The size of your bus, the seating arrangement as well as the climate your unit will be operated in were all considered and influenced what was chosen for your system.

Due to the many configurations of our air conditioning your controls may be manual or digital and either be placed on the dash or in the front overhead panel.

The passenger system(s) may be an independent system(s) or a slave to the factory air conditioning or heating system, meaning it will not work unless the factory system is turned on. The instructions for the factory system will be found in your chassis owners manual.

Please note: To gain maximum cooling and heating, we recommend that you use the in-dash system along with the passenger system.

If you have questions on how your system works please call Forest River Bus Customer Service and /or the Air Conditioner Manufacturer for assistance.

Fast Idle

This system is to be used to protect the batteries by increasing the RPM while the unit is idling. Depending on your unit, the fast idle maybe an aftermarket or a chassis installed feature.

- The aftermarket system will be either a dash switch that is labeled "fast Idle" or a digitally control system located on the dash.
- Depending on the chassis chosen the fast idle may be located by your cruise control system, or it may be in other areas. Please refer to your chassis manufacturer owner's manuals for complete instructions on how to control the fast idle.

Before using the fast idle control function the following conditions must be met;

- The vehicle is idle and the accelerator is not being pressed.
- The park brake is set.
- The brake pedal is not pressed.

To disengage the fast idle, press on the brake pedal and release the emergency brake.

NOTICE

Always disengage the parking brake before you move the unit. Driving with the parking brake on can overheat the brake system and cause premature wear or damage to the brake system parts.

Interior Operations and Maintenance

The best method to preserve the appearance and extend the life of the interior components of your bus is frequent and thorough cleaning of the different components. Cleaning and maintenance schedule requirements should be determined on the type of service conditions in which the unit is operated.

Walls and Ceilings

The front cab area of your unit will have a combination of the vinyl or cloth covered panels and ABS components. The walls and ceiling will have vinyl or cloth covered panels or panels that are covered with coordinating fabrics.

Maintenance

- Daily inspect the walls and ceiling for small tears, excess wear and damages. Have repaired as necessary.
- Inspect the fastener and/ or securement for loose or missing parts. Have secured or replace as necessary.
- Vinyl Covered Panels - Clean with a soap and water solution or for stains and heavy soiled areas you can use a vinyl cleaner.
- Fabric or Carpeted Panels - Clean by vacuuming or with a warm water and soap solution. If using a spray fabric cleaner be sure to test a small area to make sure it is color safe before using throughout.
- Plastic (ABS or FRP) material should only be cleaned with a warm water and mild soap solution

Flooring

Floor covering is a smooth Gerfloor or you may have the option of an Altro and RCA rubber flooring. The lower sidewall has Shaw charcoal carpet covered trim panel and white nosing on the entry steps. Cove molding is standard on Glaval Bus only.

Maintenance

- Inspect daily for cuts, tears, damages or lifted or frayed areas. Repair or replace as necessary
- Regularly clean the flooring. The frequency would depend on the traffic or use.

Gerfloor:

- Dust and loose debris with a vacuum cleaner.
- Mop floor using clean water with 2 to 5% neutral detergent. Detergent's dilution should be done according to manufacturer's instructions.
- Rinse the floor with clean water a thoroughly rinsed mop (be sure to rinse well with clean water) and let dry.

Altro floor

- Sweep or vacuum floor surface to remove all loose dirt and debris.
- Apply AltroClean 44™ onto the floor and allow a few minutes for the cleaner to attack the surface soil. The dilution rate depends upon how dirty the floor is.
- Scrub floor with a rectangular Altro UniPad™ or a deck brush attached to a mop handle.
- Remove the dirty water with a wet vacuum, a rough floor mop using a double bucket, or squeegee.
- Rinse the floor with clean water (ensure the floor is rinsed well with the clean water) and let dry.

Rubber Flooring

- Vacuum debris.
- Use a damp mop with warm water and non-ionic detergent . Carefully follow the manufacturer's recommended procedure.
- Vacuum, mop or squeeze the detergent solution from the floor before rinsing the surface with a solution of 10% liquid chlorine bleach (or equivalent) in warm water and let dry.

Interior Luggage Racks (Optional)

Your bus may be equipped with a luggage rack(s) or overhead luggage racks. The framing rails for the luggage racks are stainless steel. The shelving portion is covered in Dorsett aqua turf met grey carpet. The overhead luggage racks can be covered in fabric or vinyl with Shaw charcoal carpet interior (base where luggage sits).

It is the drivers responsibility to ensure the luggage is secured properly before putting the bus in motion and make sure that the luggage is secured and is not hanging over the edges. If not properly secured the luggage could fall during the ride or a passenger could walk into the items hanging over the edges.

Maintenance

- Daily inspect the racks to ensure that the attachment bolts, screws and mounting hardware and panels are intact and secure. Replace any missing or damaged items and secure any loose items or panels.
- Routinely inspect lights for proper operation. Replace bulbs or fixtures as needed. Lights Lens - Clean using a standard window cleaner.
- Stainless Steel - To clean wipe down with a damp cloth of warm water and soap solution and dry completely. Window cleaner may also be used, be sure to dry completely after cleaning. .
- Fabric Panels - Clean by vacuuming or with a warm soap and water solution. If using a spray fabric cleaner be sure to test a small inconspicuous area to make sure it is color safe before using throughout.

WARNING

Before moving the vehicle check to see that the luggage in the overhead compartments and/or the open-style luggage rack is secure and is not hanging over the railing. Luggage and other objects that are not secure could fall and injure someone.

WARNING

Reposition any item that is hanging over or sticking out past the railing/racking system into the aisle. Someone walking down the aisle way could run into them or be hit and injured.

Stanchion/Modesty Panel or Grab Rails

Your unit is equipped with a passenger side stainless steel stanchion with a vinyl covered modesty panel located on the front curbside entry door to provide extra support for your passenger when entering and exiting the bus.

Maintenance

- Daily inspect all attachments making sure all fasteners mounting bolts and screws are intact and secure. Replace any missing or damaged items and tighten any loose areas.
- Stainless steel - To clean wipe down with a damp cloth of warm water and soap solution and dry completely. Window cleaner may also be used, be sure to dry completely after cleaning.
- Vinyl Covered Luan Panels - Clean with a soap and water solution or for stains and heavy soiled areas you can use a vinyl cleaner.
- Fabric Panels - Clean by vacuuming or with a warm soap and water solution. If using a spray fabric cleaner be sure to test a small inconspicuous area to make sure it is color safe before using throughout.

WARNING

Do a daily check to ensure the attachments for the stanchions and grab rails are tight. The continual use as support could allow the screws and attachments to become loose. Loose attachments and or screws could cause someone to loose their balance and fall injuring themselves or others.

Seating and Components

Front Seats:

The style of seat in your unit is dependent on the make model and option content of your bus. Your bus may have a seat that is provided by the Chassis Manufacturer that may or may not have been ordered with an after market cover to match your other seats. You may also have a driver seat or a front passenger seat that was provided by an after-market or independent seat manufacturer.

Chassis manufacturer's seat information will be located in the OEM Owner's manual. After market is located below. Due to the many styles of seats, the applications listed below may not apply to your particular seat.

Manual Seat

Forward and Backwards

- Grab the slide release bar located underneath the front of the seat.
- Pull up on the handle and slide the seat to the desired position.
- Release the handle to lock the seat in place. Try to move seat back and forth to ensure it is in a locked position.

Reclining the Seatback

- Grab the seat recline adjustment lever on lower side of the seat. The location (side) depends on the style and options on your seat.
- Lift the lever and lean back or forward to adjust to the desired position.
- Release the lever to lock the seat back in place. Push and pull on the seatback to make sure it is locked.

Lumbar Support

When the driver's seat is equipped with a lumbar support system the knob in which you control the system can be either on the left or the right side of the seat bottom, depending on the seat style.

- For more support, increase the firmness by turning the support control knob clockwise
- For less support, increase softness by turning the control knob counterclockwise.

Power Seat

The levers or switches will be located on the side of the seat. The location and number will be dependent on the style of seat and options selected.

Forward and Backwards and to Raise and Lower

- One lever/switch will move the seat forwards or backwards and up and down to raise and lower the seat.
- Press the switch/lever forward and backwards to move the seat .
- Press the adjustment lever up and down to raise and lower the seat.

Reclining the Seatback

- One lever/switch will move the seatback up and down as needed.

WARNING

- NEVER adjust or recline your seat while the vehicle is in motion. The sudden move could startle or confuse you which could result in you losing control of the vehicle.
- All seat release mechanisms must be firmly engaged and locked when the units in motion to avoid the seat to suddenly move and startle or confuse you which could result in you losing control of the vehicle.
- Sitting in a reclined position when your vehicle is in motion can be dangerous. Even if you buckle up, your safety belts can't do their job when you're reclined.

Passenger Rear Seats (Style is Optional)

There are several styles and types of rear passenger seats that can be provided for your unit. The number of seats for each model varies according to the options chosen, the length of the bus and other factors, such as Gross Vehicle Weight etc. (listed on your front door jam).

Note: The number of seats determines the amount of passengers allowed. The tag on the driver's visor notes the number of seat positions for the vehicle.

Due to the different types of seating available, we are listing just a few of the most commonly used styles. Instructions of operation are listed on many flip and fold down types of seats.

Flip Seats

The bottom seat cushion locks in both the up and down position, and is easily released with just the pull of one lever.

To flip the seat bottom up or down

- Grab the handle under the front corner of the seat and pull forward.
- Pull the seat to the upright position against the top portion of the seat.
- Release the handle to lock into place.

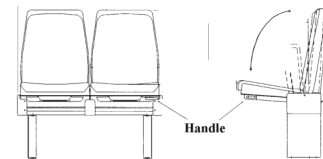

To release seat

- Grab the handle.
- Pull the lower cushion back down into place.
- Release the handle to lock into place.

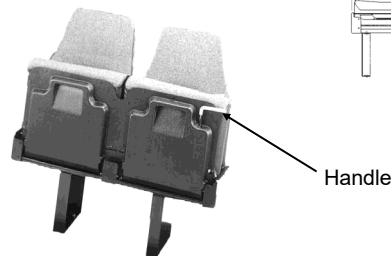

Fold-Away Seat

This seat is designed to mount using only four bolts to the floor allowing the complete seat to be up against the wall leaving the floor area free from obstructions such as the legs

To raise the complete seat

- Push lever "A" forward and fold the back cushion down against the seat cushion until the lever has snapped Back into the locked position.
- Push lever "B" upward and lift the seat into the foldaway position. Rotate the truss lock "C" to lock the assembly in place.

To lower:

- Rotate the truss lock "C" to unlock the assembly the push lever "D" and pull the top of the seat toward the aisle until it is locked in the down position
- Push lever "A" forward and lift the back cushion until the lever "A" has snapped back into position.

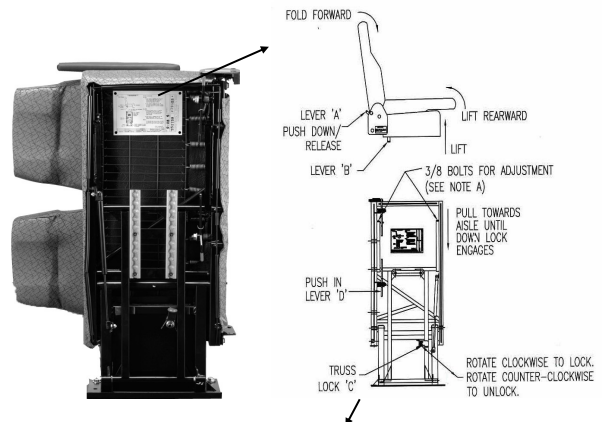

Note: Directions are on the bottom of each of these seats.

WARNING

Before moving the vehicle check to see that the seats are properly latched and secure. A seat that is not secure could come loose and hit someone which could lead to serious injury and or death.

Armrests

Flip Style:

- To move up and out of the way lift the arm upwards
- To position the armrest for use push down on the armrest.

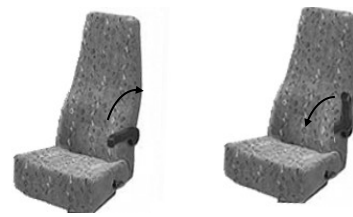

Fold Down Style

- To move to the down position “Non Use Position” pull arm up towards the back of the seat and then push the arm all the way down.
- To move to the “Use Position” Pull the arm up until it clicks and locks into place.

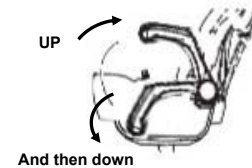

Seat Recline/Side Release Handle

- Handle is located on the outer seat bottom cushion
- Pull the handle up and lean back or forward until you reach the desired position
- Release the handle to lock in place.

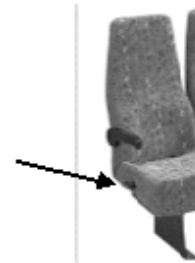

Side Slide Seats (To adjust for more room)

- Slide out for more room grab the slide handle located under the seat.
- Push the handle toward the inner side of the seat(s)
- Push outward or inward depending on the position desired
- Release the slide handle to lock into place



Maintenance

Seats

- Daily inspect the mounting bolts for seats, and when applicable seat belts. Make sure they are intact and tight and that seat belts work properly.
- Inspect to insure the seats frames are not broken or loose and the seat cushion are secure to the frame.
- Lubricate all mechanisms and inspect for proper operation.

Fabrics

- Daily inspect the seats for ripped, torn, frayed or damaged areas. Replace or repair as necessary.
- Regular cleaning, at least once a month, can prolong the life of the fabrics.
- Vinyl Covered Seats can be cleaned by using mild vinyl cleaner or a soap and water solution.
- Leather Covered Seats can be cleaned with a damp cloth or a leather cleaner, followed by rinsing and wiping down the seats. Other cleaners may damage fabrics, such as causing the vinyl to dry and can cause cracking of the material. Read the label information carefully.
- Fabric Covered Seats can be cleaned by using a vacuum, clean spots with a soda and water solution recommended for fabrics. To remove odors and or deep clean the fabrics you can use a steam cleaner.

Exterior Components and Maintenance

The following section explains the basic features of the exterior components and will help you to become familiar with the bus operations and procedures.

A bus needs to be protected from outdoor elements that can wreak havoc on the paint and body of any bus. Throughout this manual are some exterior maintenance procedures that must be performed to help maintain the integrity of the bus.

Washing

The exterior finish needs to be kept clean by frequent washings. Do not ignore the under bottom of the bus particularly behind the wheel wells which can hold an accumulation of dirt and salt particles that needs to be removed.

- Do not wash the unit in the direct rays of the sun.
- Rinse the entire bus with lukewarm or cold water to remove loose dirt.
- Use a mild liquid detergent for all areas. Never use a strong soap or chemical detergents. Solutions containing acetone, lacquer thinner or other solutions can destroy the high strength of many plastics and seals.
- To prevent a section from drying too quickly and leaving deposits or residue wash one section at a time working from top to bottom.
- Rub the surface to gently loosen dirt. Please note: Vigorous or aggressive rubbing can grind dirt into the finish, leaving scratches and swirls. A pressure washer can damage the paint, decals and graphics.
- Frequently rinse your wash mitt, sponge or brush, this will greatly reduce the possibility of contaminants becoming embedded in your cleaning tools and creating scratches and swirl marks.
- All cleaning products should be flushed from the surface and not allowed to dry on the finish.
- Remove tar, bugs, sap, bird droppings and road chemicals as soon as possible to prevent staining. If a simple wash does not remove these deposits you may need to use additional cleaners made for these types of debris. Be sure to test these products in a small area before using.
- Perform a complete underbody flush as least every 30 days. Note: When operating on roads that have chemicals such as road salts it is critical to wash the complete body and components and to perform a through underbody flush on a weekly basis.

NOTICE

Solutions containing acetone, lacquer thinner or other solutions can destroy the high strength of many plastics and seals. When using chemical cleaners developed for this purpose, be certain they are safe for the specific surface. Before using any product test a small area to be sure it is safe.

Pressure washers may cause damage to the finish and/or any graphics that may be applied. If you do decide to use pressure washer and you are using a recirculation system make sure there is a filter in place. If the filter is not in place the grit can travel through the system and can cause damage to the outside of the bus .

NOTICE

Calcium chloride (salt) and other ice melting chemicals if allowed to stay on the surface will harm the surface and corrosion can occur. Tar, road oils, pollution, bugs and bird droppings can damage the paint. Remove all as quickly as possible.

Waxing

Your vehicle should not be waxed within 90 days of the manufacture production date of the bus. The complex chemistry of today's automotive paints continue to cure and harden during this time.

NOTICE

Applying a wax within 90 days of the manufacturers production date can result in damaging the integrity of the paint.

Waxing and polishing the bus regularly will reduce deterioration caused by the outside elements such as air pollutants and prolonged exposure to the sunlight.

- It is recommended to Wax your unit at least every 6 months to protect the paint. (Refer to Vinyl Graphics below)
- Do not wax while the bus is in direct rays of the sun.
- Wash the complete unit to remove all of the dirt and grime off and completely dry before you begin waxing.
- For the steel body: We suggest you use a high-quality hand-applied nonabrasive wax designed for automotive finishes on the body and fiberglass parts of your unit.
- FRP, "ABS and Fiberglass: We suggest you use a marine grade polish.

Exterior Paint Care

After the final curing period (at least 90 days of the manufacturers production date) a high-quality hand-applied wax designed for automotive finishes may be used on the body and fiberglass parts.

- Refer to page 17 for additional information on washing the unit.

Vinyl Graphics and Decals Care

To avoid the possibility of damaging the vinyl graphics only clean with a mild detergent or nonabrasive cleaner designed for automotive finishes. Automotive wax should not be applied to the graphics or decals, it may result in an unattractive buildup.

- Do Not use mechanical power spray directly on the Vinyl Graphics. Using a high powered spray washer directly on the Vinyl Graphics could result in tearing or lifting of the vinyl graphics and using wax could dull color.

NOTICE

Using a high powered spray washer directly on the Vinyl Graphics could result in tearing or lifting of the vinyl graphics and using wax could result in an unattractive buildup to the color.

- Use a soft cloth and cleaners that are not abrasive so that the graphics or decal do not become scratched during the cleaning process.

Chrome, Stainless Steel and Aluminum Parts Care

- Use only automotive approved nonabrasive cleaners and polishers on exterior bright work.

Sealants/Caulk

The sealants and adhesives used on the seams are formulated to remain waterproof under the sustained effects of the weather and road vibrations.

Maintenance

- Inspect all seams and moldings for missing areas, damages, scrapes, cuts or cracking at least every 30 days.

NOTICE

Scrapes and missing pieces left untreated can allow water to seep through the seams and molding getting between the sidewalls or under the paint causing damage and also enter into the interior causing damage to the walls and other components. The lack of maintaining these items can void your warranty.

Body Panels, Roof and Caps

The roof exterior skin is made with a fiberglass composite. Depending on your unit the front and rear caps are either fiberglass or ABS, and the sidewalls and skirts are either steel or a fiberglass component.

The roof and cap areas are very susceptible to scrapes and cuts by tree limbs or other overhanging obstructions. Rocks and other debris can cause damage to the other exterior areas.

The skirts (lower body) or wheel wells can be damaged by curbs, road debris and accidents. It is important to check for damages that could inhibit driving the unit for example; if the skirts are damaged check to be sure they are not rubbing or restricting the tires in any way.

DANGER

Check for damages that could inhibit or alter driving the unit. If the tires are restricted or rubbing it could result in an "air-out" situation and the driver could lose control of the vehicle which could lead to an accident severely injuring or killing others in or around the vehicle

Maintenance

Remove tree sap, seeds, gum resin, asphalt, etc., as soon as possible with washing. These environmental materials will bake and harden in time and become difficult to remove without buffing

- Use a nonabrasive cleaner to help remove accumulated residue and eliminate any "weathered" appearance.
- At least every 30 days inspect the areas for deep scratches or dings in the exterior. Units that are driven 12 to 24 hours daily need to be checked weekly.
- Have damages, scratches and dings repaired as soon as possible, especially if the underlying metal is visible.

Exterior Damages

If damaged and scratched areas are left untreated they will deteriorate. If the metal is visible and exposed to the elements it can rust at a rapid pace, ultimately damaging the bus exterior and leading to expensive repairs. If the fiberglass composite on either the roof and/or the wide wall areas is chipped water can seep under the finish causing it to lift off or to pit.

Metal Body surfaces

- Inspect the body at least every week for chips, scratches or other damages.
- Very small exposed areas may be touched up with paint.

Fiberglass Composite

- Inspect the body at least every week for chips, scratches or other damages.
- Very small scratches can be removed by using a rubbing compound followed by a marine grade wax
- Larger damages or exposed areas should be repaired by a qualified repair facility.

NOTICE

Rust and corrosion and/or water intrusion due to dings, scratches and/or other damages that were left untreated or repaired will not be covered under warranty. Water damage that is due to scrapes or cuts and damages that were left untreated and/or the lack of maintenance of the exterior seams and molding ultimately damaging the bus will not be covered under warranty.

Windows

The style of the egress windows in your bus is dependent on the model, and size of your bus, along with the options selected. Your unit may be equipped with either a T-Slide style windows with vents that open or full view frameless windows. The bus may also be equipped with cockpit windows or a driver cockpit window along with full view Starview window on the passenger side.

Emergency Exit (Egress) Windows:

The style of the egress windows in your unit will either be a full view flush-fitting window or a full view window that has sliding glass at the top or bottom of the window.

These windows can be located on either the side or the rear area of the bus.

These windows are designed to allow the passengers to release the latch(s) and push the window to crawl out in the case of an emergency situation.

All emergency windows are equipped with one or two bright red handles, along with the instructions on how to open them in an emergency.



Example of location of Red Release Handles

Inspection and Maintenance of Emergency Windows

Inspect Daily all Emergency Windows

- Check the operation of each egress window. Open all handles and push out the window to ensure it is working properly do not extend the window beyond 40 degrees. Pushing any window out too far can cause it to release and fall out; as it would in an emergency situation.
- Inspect the latches and mechanisms if they are damaged, worn or have loose parts, replace as necessary.
- Lubricate any hard to move latches with white lithium grease.
- Inspect the glass for cracks and chips, replace if damaged.
- All emergency windows are labeled as Emergency Exits and the instructions are provided *by each handle*.
- Inspect the seals for damages and worn or loose areas and replace as necessary.

WARNING

Check for proper operations and ensure that the instruction labels are intact. Serious injury and or death could occur if the window operations fail and people are not able to escape during an emergency.

WARNING

Do not drive with the egress windows unlocked/unlatched or allow someone to open them while the unit is in motion. Driving a bus with the Egress windows unlocked could result in the window blowing open and falling out. The window also could become airborne. Either condition could lead to serious injury or death..

NOTICE

Windows that are damaged due to the window handles not being secured or being that the window was pushed out to far causing it to fall will not be covered under warranty.

Passenger Windows (Non Egress)

The style of the non egress passenger windows in your bus will either be a full view flush-fitting non-opening window or a full view window that has sliding glass at the top or bottom of the window.

Note: Maintenance will be listed at the end of this section

T- Slide Windows:

If your unit is equipped with these windows they will slide towards the center to allow air to flow into the unit.

- To Open pull out on the t-slide release latches on each vent and slide the window towards the middle.
- To Close push the windows back into position and push the handles back into place to lock.



T- Slide Release Latches

Full View Curb Windows/ Starview

This is a stationary window. It is located in front of the entry door curbside which helps the driver to see the curb and any passengers in the area while he is in a seated position.



Cockpit Window

If your style of bus does include a driver entry door your unit will be equipped with a driver cockpit window that has a sliding glass. These windows can also be located on the passenger side.

These windows will have one or two latches that will lock the window.

- To open lift the latch(s) upward to unlock the window and slide the window.
- To close simply slide the window back into position and pull the latch(s) back down into the closed position.

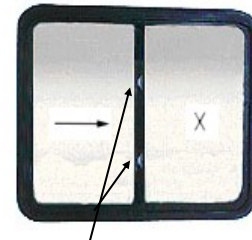

Shown with 2 Release Latches

Windshield

All windshields are original equipment manufacturer (OEM) windshield installed by the chassis manufacturer.

Maintenance

Window Glass

- Do a daily inspect to ensure there are no damages, cracks or chips that could result from road debris such as stones.
- Wash with a mild soap and water or a commercial window cleaner.
- For heavy residue apply straight mild detergent to a soft cloth and wipe the glass.
- Dry with a clean cloth. Next, clean the glass again, using a clean cloth with a 50-50 mix of water and a household window Cleaner. If there is still a residue, remove it with rubbing alcohol dry and then use the household cleaner.

Window Seals

- Inspect seals for damages and or worn or loose areas and replace as necessary.
- To clean the seals use a silicone based spray which will also condition the seal.
- To remove heavy film and grime clean with isopropyl alcohol followed by cleaning with a mild soap and water rinse and then apply the silicone based spray to the seals.

Window Weep Holes:

Weep holes allow the water to flow out the bottom portion of the window. These areas may accumulate dirt and debris that over time can clog the weep hole. If they are not cleaned water can seep into the interior.

- Remove dirt and debris by inserting a small thin object into the drain hole to remove an obstruction

Window Sliding Track

The slide track may accumulate debris which can stop the sliding action and or make the window very hard to open.

- Vacuum or use an air compressor to blow out the tracks
- For heavy debris use needle nose pliers to remove.

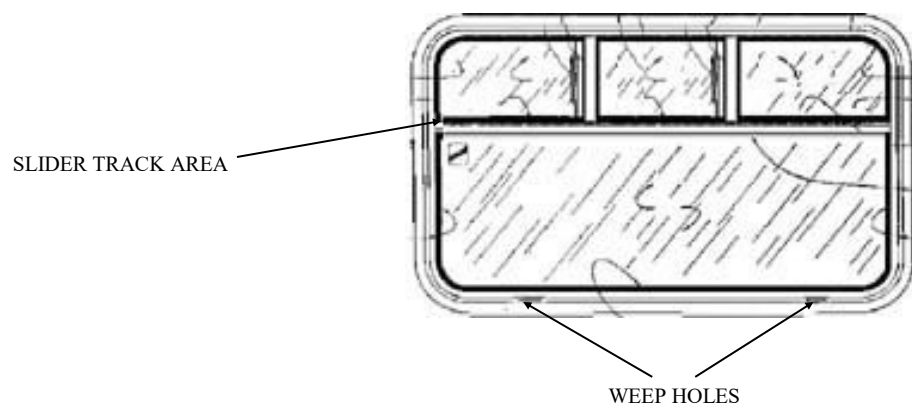

NOTICE

Abrasive cleaners can scratch and or damage the glass and the seals. Do not wipe dirt off dry windows as it can scratch the glass.

Exit Doors

Not all doors are designated as emergency exits. Designated emergency exit doors may be located on the side or rear of the vehicle marked with an **“EMERGENCY EXIT”** decal/plate either on the door or above the door.

Maintenance for the doors is listed at the end of the door information.

Driver or Front Passenger Door (OEM)

If there is a driver door and or a front passenger door (co-pilot) on your unit these doors are provided and installed by the original chassis manufacturers.

Manual BI-Fold Entry Door

This is a two panel door that separates to permit entry and exit. It is equipped with a manual door mechanism located in the cab next to the driver. The handle and actuated door arm allows the driver to open and close the door with a back and forth movement of the handle.

To ensure the door does not open there is a retaining lever that holds the door handle in place.

Operations

- To open: lift the retaining lever holding the door handle in place and push the handle outward.
- To close: pull handle back until the handle is properly secured into the retaining lever.

WARNING

Do not block an emergency exit with luggage or other items that could restrict the use of a door in an Emergency. The result of injuries can be much worse and/or result in death if an evacuation is necessary and the escape routes are altered or obstructed.



WARNING

Driving without the handle properly secured in the retaining lever could allow the door to open causing someone in or around the area to be hit which could lead to serious injury or death

NOTICE

Driving without the handle properly secured in the retaining lever could allow the door to open and damage the door or the handle.

Electric BI-Fold Entry Door

This is a two panel door that separates to permit entry and exit and is equipped with a electric mechanism opened by pressing the door switch. The door control switch will be the closest switch to the driver in the switch panel, and location will vary per model. The switch panel will be either on the driver's console or overhead.

Operations

- To open press up on the door control switch to activate the electric motor, the door will open outward; and automatically stop when fully opened.
- To close Press down on the switch to close the door. The door will automatically stop when fully closed.

Note: The engine does not have to be running for the door features to work. Example of a door switch



Emergency Door Release Handle/Button

CAUTION

Doors open outward which could cause someone to be injured. If they are in the area of the door they could be struck or hit by the door while opening. Before opening make sure the outer area is clear.

This handle and or button is to be used in the case of loss of power. It is located above the power entry door along with instructions on how to disengage the mechanism which allows the doors to be opened manually.

Red Release Handle:

- To operate pull the handle outward which will disengage the power mechanism and allow the door to be pushed open.

Note: Be sure the handle is engaged before you drive the vehicle.



Release Handle

Red Release Button:

- To operate push the button in to disengage the power mechanism and allow the door to be pushed open.

Note: Be sure the button is pulled out and engaged before you drive away.



Release button

NOTICE

Driving without the handle properly or button properly secured could allow the door to open causing damage to the door and the exterior of the bus.

Electric Entry Door Key Switch

This key switch allows you to open and close the door from the outside of the bus. The standard position for the switch is on the left side of the entry door mounted on the body of the bus.



Key Switch

- To open Place the key in the lock and turn to the horizontal position and hold until the door is completely opened.
- To close turn the key back to the vertical position and hold until the door is closed..

Electric Exterior Toggle Switch

If ordered the toggle switch location can vary depending on how it was ordered. The switch may be located on the exterior of the unit behind the passenger entry door or on the passenger front pillar by the windshield.

- To open and or close push the toggle switch sideways to activate the door.



Toggle Switch

Lift Door

This door is used to access the lift and can be either a one or two panel door. Each door panel has a window and there is a locking handle on the outside of the door. An interlock sensor is added to ensure the bus will not move when the door is open. For more information regarding the interlock system refer to **Rear Doors and Lift Door Open Warning System**

- The door must be closed before moving the unit.
- There will be a red light on the dash that will illuminate when the door is open and a green light when the lift is engaged.

Note: The lift will not be functional until the door is open, the engine is running and the park brake is set. For more information on the lift operations refer to your Lift Manufacturers Owners information.

Daily Check each Emergency Door and Lift door:

- Check the light and/or alarm by opening the rear door and turning the ignition key to the on position.
- Check the operation of the red handle or the push knob to insure the doors do release and you can open the doors by simply pushing on them.

Lift Door Accessories:

An ADA light is added under the lift door and illuminates once the door is open or ajar. Your unit may be equipped with the following hold open systems that will help hold the door and prevent the door from hitting the side of the bus.

- Plunger & Socket Style is designed to grasp door, hold back plunger by pushing the door plunger in to the socket to hold open and pull the door to release.
- T-Latch & Catch style in which the t-handle slide is placed into the catch. to keep the door open. Take the slide out of the catch before closing the door.



Plunger & Socket



T-Latch & Catch

Rear Exit Doors

Standard Rear Door

The standard rear door may be a single or dual panel door and can be equipped with windows and door handle (s). The door handle will have an L- Style handle that will turn to open and turn back to close. There is a shock installed at the top of the door to help secure the door when it is opened.

Rear Emergency Exit Door

A rear door that is designated as an emergency exit will be clearly marked with the “EMERGENCY EXIT” decal or plate, either on or near the door.

This door is equipped with a non-locking door handle as per the **Federal Motor Vehicle Safety Standards (FMVSS)**. The rear emergency door needs to be accessible, properly marked and to be opened by simply lifting the handle and pushing the door outwards to avoid anyone from being trapped in the bus.

Do not replace the door latch/handle with a locking style, by doing this you will be violating the FMVSS regulations and creating a dangerous situation for your passengers.

WARNING

Do not change the non-locking handle to a locking style. If you allow the Rear Emergency Exit door to be locked while the vehicle is in use you will be putting you and your passengers in jeopardy of being trapped in the vehicle in the case of an accident. This could lead to serious injury or death.

Daily Check Each Emergency Door

- Check the light and/or alarm by opening the rear door and turning the ignition key to the on position.
- Check the operation of the red handle or the push knob to insure the doors do release and you can open the doors by simply pushing on them

Rear Door Interlock System (Optional)

Your bus may be supplied with a vandal resistant latch that works in conjunction with an interlock system to prevent movement of the vehicle when the interlock micro switch is activated (door latched at the top). The vandal sliding bolt system is located on the interior, on the rear emergency door, and is used to help prevent the door from being opened from the outside. To latch simply push the red handle upwards.

When the slide bolt is pushed up it makes contact with the interlock assembly (micro switch) which sends a signal that will prevent the engine from starting and/or will not allow the transmission to go into gear. If the switch is activated and the Ignition key is turned an audible alarm will sound and the dash light will illuminate in the driver's area.

Note: The performance of the interlock will depend on the option purchased.

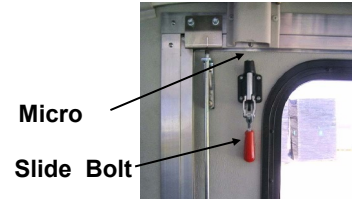

Shift Interlock System: If the rear emergency door interlock switch is activated and the bus is started the micro switch sends a signal to the transmission that will not allow the bus to shift into gear. There will also be an audible alarm sounding and the light will illuminate to alert the driver of the situation. The interlock releases when you pull the slide bolt down.

Starter Interlock System: If the ignition key is turned while interlock switch is activated the micro switch sends a signal that does not allow the bus to start. It also will sound an audible alarm and illuminate a light to alert the driver that the door is locked. The interlock releases when you pull the slide bolt down.

Daily Check

- Check that the lock rod is making proper contact with the micro switch and that the components are secure.
- Test the signal by locking the door and turning the ignition key to the on position making sure both the light and the audible alarm sounds.

Rear Doors and Lift “Door Open” Warning System

A rear door will be equipped with a light on the dash that operates if the door is open and ignition key is turned to the “ON” position. The rear door may have the option that includes a rear audible alarm that will sound along with the dash light if the rear door is open and ignition key is turned to the “ON” position.

Maintenance

Before each trip inspect the door operations to ensure they are working properly. The following are items that need to be frequently inspected to ensure the doors remain in good working order.

Manual Door Operations

- Inspect daily the door mechanism for loose or damaged parts.
- Open and close to see that the door is moving smoothly closes properly and the door mechanism (handle) latches properly when closed.
- Repair, replace or adjust as necessary.

Electric Door Operations

- Inspect daily to ensure the door power mechanisms are working properly.
- Open and close the door using the console switch and then again using the exterior key switch. If door is not operating properly have adjusted or repaired as necessary.

Lift door/ Interlock system

- Check daily for proper operation.
- Slightly open the door, check that door light is functioning, then try to move the door forward and/or backwards.

Door Alignment

- Check daily to ensure the door is closing properly and check to ensure the seals are in proper alignment when closed.
- Check all nuts and bolts for tightness and have realigned as necessary.

Door handle operation

- Check daily, adjust or replace as necessary.

Lock sets, Latches and Hardware

- Check daily for damage or worn areas, replace as necessary.
- Apply lubricants to the following at least every 6 months. If vehicle is exposed to salt air lubricate more often.
 - Key holes .. Lubricate with powdered graphite squirted directly in the keyhole.
 - Latches .. Lubricate with a white lithium grease and any contacting mechanisms
 - Hinges... Lubricate with a Silicon-based product directly applied to the hinges.
 - Door Pins.. Lubricate with a light machine oil.

Glass Panels/Windows

- Daily inspect for damage or looseness.
- Clean daily or as needed. Use a standard ammonia based solution or glass cleaner and a soft cloth to remove road film and dirt.

Brushes and Pivot Points

- Inspect daily for damaged, worn or loose parts.
- Tighten any loose areas such as bolts, hinges, pins, nuts etc. or replace parts as necessary.

Aluminum Components

- Clean as needed. Use a mild all purpose cleaner and wipe dry.

Door Seals

- Check daily and replace if damaged or worn.
- Use a silicone based spray weekly to lightly coat the door seal surfaces.

Rubber or Neoprene Extrusions

- Check daily for cracks and worn areas replace as necessary.
- Clean regularly using a nonabrasive, noncorrosive all purpose cleaner, followed by a vinyl protector.

Exterior skins

Repair any damages scratches and dings on the smaller doors, luggage doors etc.

PASSENGER ENTRY DOOR

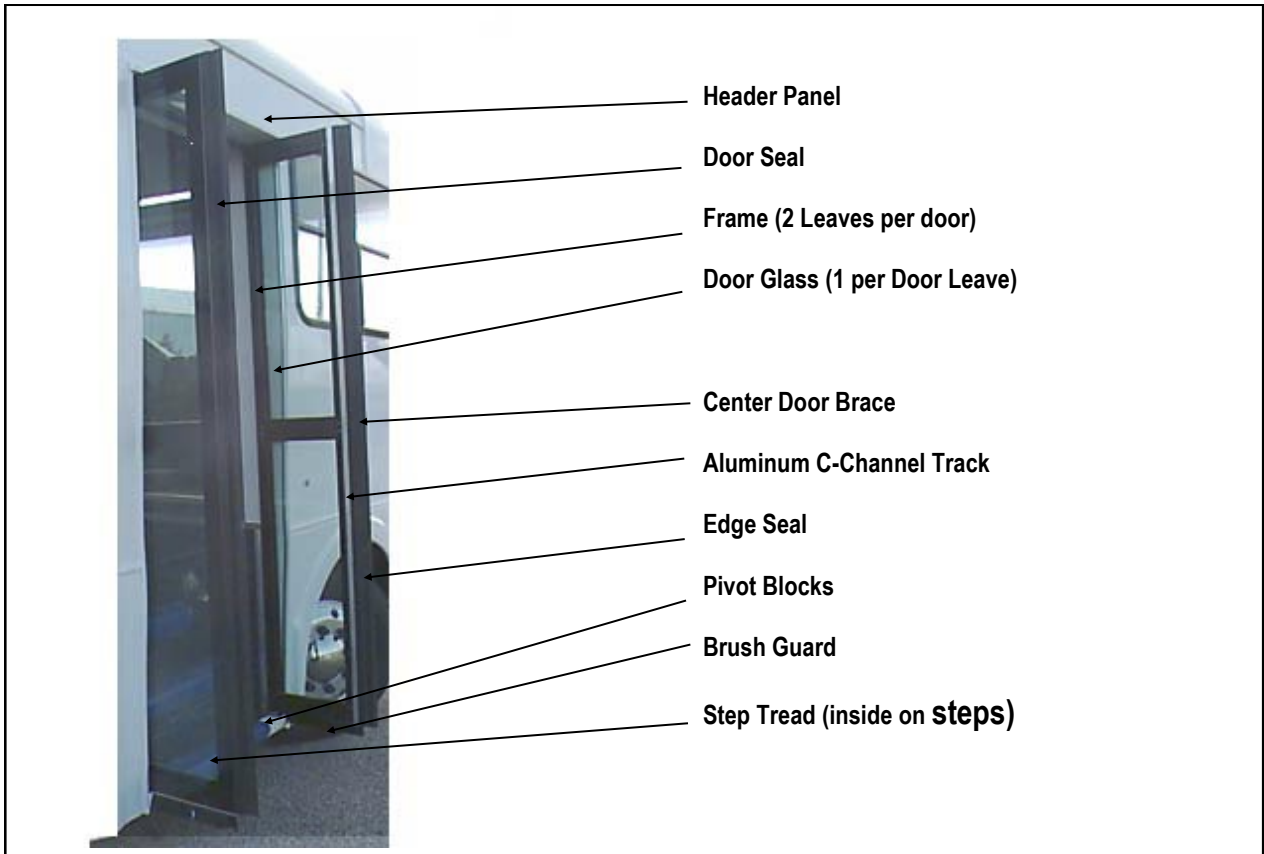

EXTERIOR LIFT DOOR



INTERIOR OF LIFT DOOR

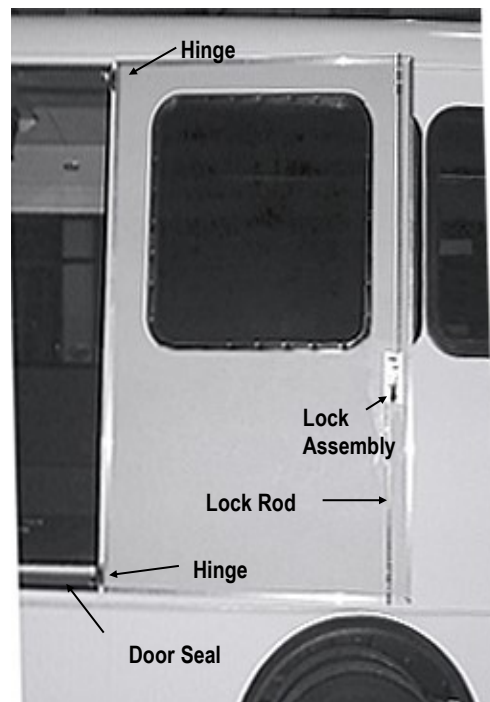

Exterior Mirrors

Depending on the model and the options in your unit you will have either a manual or power style Mirror. The mirrors need to be adjusted so the driver can get the maximum view around and behind the vehicle.

The lower portion of the mirror is a convex meaning the surface is curved so more can be seen from the driver seat. The convex portion of the mirror can make things, like other vehicles, appear to be farther away than they really are and caution must be taken when changing lanes.

WARNING

Each driver needs to adjust the mirrors to ensure they are positioned to accurately see motorists, objects and people near and around the bus. Failure to adjust the mirrors properly can lead to an accident causing serious injury or death.

Manual mirrors: Adjust your mirror manually by pushing it up, down, left or right as needed. On the lower portion of the mirror is an auxiliary convex mirror adjust manually by pressing the mirror. The mirrors can also be folded in or out.

Power and/or Heated Mirrors: The make, model and option will determine what type of switch your unit will have and where it is located. You will be able to move the upper or lower convex portion of the mirrors independently. The heat switch is a separate switch located in the same area as the adjustment switch. Here are some examples other options may apply:

Heater switch
Push red side for heat.

Dual Function Mirror Switch
Select Left or Right mirror
Adjust by pressing up or down
and left and right



Heater switch
Push red side for heat.

Single Function Mirror Switch
Select Left or Right mirror
Adjust by pressing up or down
and left and right

Inspection and Maintenance

- Inspect daily to ensure that the mirrors heads brackets and support arms are secure and the bolts and mounting brackets are not damaged or loose. Secure or replace items as necessary.
- Adjust daily to ensure there is a clear view for the driver.
- Check power operations mechanisms where applicable. Adjust as necessary.
- Clean the glass with standard glass cleaner and the mirror head and brackets can be cleaned with a nonabrasive detergent.
- Replace any blown or damaged bulbs and/or fixtures and missing reflectors immediately.
- Check at least every 6 months for frayed or damaged wires and or loose connections.
- Clean the lenses and reflectors with window cleaner and /or a nonabrasive detergent.

Emergency Vent/Hatch (optional)

As a driver you must understand how the hatch operates. Operation procedures will depend on the style you purchase. The instructions will be listed on the hatch. Please review the provided information to understand the complete use of the hatch.

You may or may not have an exterior release mechanism depending on the style of the roof vent/emergency escape hatch. If there is not an exterior release mechanism, someone may need to release from the outside .



Maintenance

- Periodically inspect attaching fasteners to ensure that they are secure.
- To clean use a mild soap and water.
- Do not use solutions containing acetone, ether, lacquer thinner or other solutions that can destroy the properties of composites and plastics.

WARNING

Fasteners used in this assembly are special and have critical torque requirements and tamper resistant heads to discourage tampering. The Hinge assembly is critical and should never be removed from the cover assembly. Alteration of any type can cause the hatch to jamb which could prevent the occupants from escape causing them greater injuries, even death.

Hood Latch /Engine Cover

Some Freightliner models are equipped with a hood that will have two push button release locking latches to secure the hood in place. It will also have a hold open rod located under the hood to help ensure the cover does not fall down while being worked on.

- To open: push in the button on the latches to release the handle, pull up until completely opened. Secure the hold open rod on the hood .
- To Remove push up on the hood to release the rod, secure the rod in the down position and lower the hood.

Under Carriage Luggage Doors

The under carriage luggage doors are guided by two air shocks that hold the door up when completely open and will be equipped with one of the following style handles.

T-Latch Style : Unlock the handle. Pull up on the t-latch handle and turn. Once the handle is released simply lift up the door. Use the bottom of the door to open completely. Do not use the handle to lift the door.

Pull Style: To open unlock and release the handle with the key and pull the door upwards. Use the bottom of the door to open completely.

Maintenance

- Monthly or when loading luggage check the luggage compartments to ensure they are dry to avoid corrosion.
- Refer to the door "Maintenance" section on page 35 for further maintenance information.

WARNING

Use caution when opening luggage door as the luggage may have shifted while the bus was in motion and could cause the luggage to fall out when the door is opened which could cause someone to be injured.

Battery Box (Optional)

The need and location of the Battery box is determined by size of your unit as well as the option content. Boxes will be located on either the driver side or the passenger side in the side skirt area pending model.

Battery Box Door

The auxiliary battery location will depend on the make and model of your unit . These will be located in the lower skirt area. The standard doors will be equipped with a turn thumb latch. An upgraded locking door is available.

- Do a visual inspection each day to ensure and battery box area has not been damaged.
- Visually turn thumb latch or may have optioned in a locking door to ensure that there is not damage and they are properly and securely holding the door closed.

Maintenance

- At least every 30 days do a visual inspection each day to ensure the battery box and area has not been damage.
- Check to ensure the battery box is kept clean and free of corrosion.
- Check to see that the battery box is secure in its location and the cables and batteries are secured properly.

Battery Tray (Optional)

Your unit may have a pull out battery tray that provides easy access to the batteries. The tray can be either black powder coated or stainless steel.

Maintenance

- Do a visual inspection each day to ensure the battery tray and area has not been damaged.
- At least every 30 days inspect the slide mechanism and mounting brackets to ensure it is in proper working order, repair or adjust as necessary. Remove any battery acid or debris that may have accumulated.
- Check to ensure that the battery tray is kept clean and free of corrosion.
- Lubricate the slide mechanism at least every 30 days with a white lithium grease.

Battery Hold Down Straps

A standard metal battery strap is provided to secure the battery and help avoid excessive vibration which can cause premature failure of the batteries.

- Do a visual inspection each day to ensure the battery hold down straps have not been damaged.
- Check the straps to ensure they are secure and holding the battery securely.
- Make sure the battery hold downs and carrier are kept clean and free of corrosion.

Maintenance

- At least every 30 days check to make sure the brackets holding the battery to the frame are secure.
- If the battery brackets are loose, tighten them and spray them with a corrosion preventative spray to help keep the corrosion on batteries from rebuilding

Underbody Areas

Chemicals and corrosive materials used for ice and snow removal, will attack the under-carriage metal, engine components, brakes and electrical systems if not flushed from the underbody. Mud, sand, dust control and industrial pollution can collect on the underbody of your vehicle and also cause extensive damages if not removed.

The underbody damage to vehicle systems is not only a cost burden to a bus owner, it can result in a vehicle safety issue for drivers and passengers.

Undercoating is provided to help rust proof and protect your vehicle from damage due to sand, gravel, road salts, and other grime. The undercoating and the underbody of the vehicle must be inspected to maintain the integrity of the product.

Maintenance

- Undercoating should be inspected and touched up where needed on a yearly basis (every 12 months) to eliminate frame and body rusting.

Note: Units that are in service for 12 to 24 hours a day the undercoating should be inspected and repaired every six (6) months.

- An Underbody Flush must be performed every 30 days to clean off the debris, mud and other road chemicals that can accumulate on the under carriage and seams and cause rust.

Note: For areas that routinely salt the road pay special attention to the under carriage and seams where salt can accumulate and cause rust. This must be performed weekly (every 7 days) during the winter months, or more if the conditions require a heavy use of salt.

- Forest River Bus Frame Mounting Bolts: Check the bolts every six months for proper torque. These are grade 5 bolts torque to 55 to 60 Ft Lbs.
- Frame Die Springs: Check the die springs every six months making sure they measure 2 3/8" compression height. These are located at the front of the Forest River Bus / OEM body areas on each side of the frame.

Air Ride Suspension

The air ride system is a compressed air devise that supports a portion of your vehicle loads. Failure may occur as a result of punctures, impact damage, improper inflation or improper usages. Proper use and proper maintenance will help you gain the maximum benefits.

Depending on your unit the air ride suspension is either part of the factory options and or added on during the production process.

Review the manufacturers operating instructional manual for complete information concerning torque specifications, air pressures, operating instructions, trouble shooting and maintenance routine (daily)

Maintenance

- Visually inspect front to back and side to side while the unit is on level ground should be performed.
- If low, add short burst of air into the inflation valve air spring nearest to the low point until level.
- Do not exceed the manufacturers recommended levels.

OEM Air Suspension Reservoir (Ford F650, Freightliner or International Chassis)

The Air Suspension Reservoir must be regularly purged to help prevent pre-mature rusting of the interior faces of the tank. Check your chassis owners manual for the location of the reservoir dump valve.

Maintenance

We suggest purging the reservoir once a week, although the environment will be a factor in the schedule. Please contact your local Ford, Freightliner or International Dealer for further information.

Wheels

Maintaining your wheels will not only enhance the appearance, it is also essential for safety.

Periodically checking the lug nuts for tightness, wear, and tear, will help assure that you will have a safer trip plus help you avoid unnecessary damage. We have listed some suggested inspection and care information.

Be sure to Refer to the Chassis/Tire Manufacturer manuals for proper care, use and maintenance information.

- Daily inspect for damaged or loose, missing or stripped mounting bolts and or lug nuts . Repair or replace items as necessary and properly torque.
- Inspect and replace wheels that are bent, cracked, rusted or corroded.
- Clean regularly use a nonabrasive cleaner recommended for aluminum wheels.

Replacement

Refer to the Chassis. Tire Manufacturer manuals for information on wheel replacement and torque specifications.

Each wheel should have the same load-carrying capacity, diameter, width, offset and be mounted the same way as the one it replaces.

- You must use the same size and types of tires on all wheels. Do not Mix different sizes or types of tires (radial and bias-belted).

⚠ DANGER

Mixing different sizes or types of tires (radial and bias-belted) can cause the vehicle to handle improperly which could cause you to lose control while driving resulting in a serious accident. You must use the same size and types of tires on all wheels.

Wheel Covers Insert (Option)

Your bus may be equipped with wheel simulators or inserts that will be placed over the chassis wheel. There are several different styles that can be added.

Chevrolet 3500/4500 and Ford E350/E450

- **Wheel simulators** snap on the outside lip of the chassis rim. To install you just need to start on one side and carefully tap on the opposite side. Pry between the chassis rim and the simulators carefully working around the sides to remove.
- **Wheel inserts** are mounted by utilizing the chassis wheel studs. To install simply put the insert into place and screw the two jam nuts on to hold it in place. To remove reverse the process using care to only turn the jam nuts and not the hallow covers. You would be able to tell the difference by tapping them and listening for the more solid of the two.

Freightliner, International and Ford F650/F750

- **Wheel Stud Extenders with Chrome Covers** Maybe used on the vehicles that have larger wheels 19.5" and larger. They simply screw on the wheel studs and provide a place to mount the jam nut. With this application the jam nut has a separate chrome cover. You must remove the chrome cover before you can unscrew the jam nut with the provided wrench.

Tires

Tires play an important role in your vehicle's road-handling performance. It is imperative that you pay attention to the proper tire maintenance which includes monitoring tire pressure, tread depth and performing regular tire rotations, these are all safety issues

When it is necessary, replace any damaged tires, valve stems etc. with the same or equal to the original parts or tires installed on your bus and stay within the guidelines listed on the Federal ID tag.

Refer to **Tire and Rim Certification Label** and **Tire pressure (page 9)** and the **Tire manufacturers Owner Information** for important information regarding safety and specifications of the tires and tire pressures.

⚠ DANGER

Do not run with over inflated or under inflated tires either of these conditions can result in poor handling or the loss of control resulting in an accident which could lead to serious injury or death..

- Over inflated tires are more prone to be punctured, cut or broken in a sudden impact (such as a pot hole) which can result in losing control of the vehicle.
- Under inflated tires are prone to the tire overheating resulting in sudden air loss or catching on fire and or the loss of control of the vehicle.

NOTICE

Damages to your tires and or wheels due to the tires being under or over inflated can result in voiding your warranty. Review the tire manufacturers warranty for complete information.

Care

- Do not allow sand, mud or dirt to build up on your tires.
- Regularly wash using with a mild soap, water and a soft brush or use a cleaner that is especially made for tires.
- Review your Tire Manufacturers Owners information for more information on properly cleaning your tires.

Maintenance

Please review your Tire Manufacturers Owner Information for complete information.

Before each trip.

- With a proper gauge check that each tire is properly inflated.
- Check all valve stems and caps to ensure they are not leaking or damaged.
- Inspect for any type of road or curb damage to tread or sidewall areas.
- Inspect both the inside and outside of the sidewalls and tread for tire of wear, cracking, cuts in the tread or sidewall and/or items that may have become imbedded into the tire such as screws.
- Check for visual signs of overloaded or under inflated tire use. These types of conditions can show up as an unusual waviness or discoloration in the side walls, bulging in the bead area near the rim flange or a progressive tread wear that is more distinct on one tire.

NOTES

